

- | Gear Pumps
- | Flow Measurement
- | Hydraulics
- | Valves

High-Pressure Gear Pumps **KP 0**

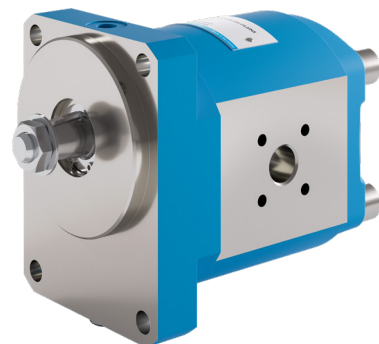

Construction

According to its design, the Kracht KP0 external gear pump belongs to the type of so-called gland type pumps. The essential functional elements, gearing and bearing glands are located in an aluminium housing of high-strength extruded alloy, which is limited laterally by the the cover plate and flange cover.

The gearing, made of case hardened steel with surface hardening, consists of the drive shaft wheel and pin wheel. The highest manufacturing quality is guaranteed by shaving the tooth flanks.

The shaft journals are finely ground. Due to the high number of teeth ($n = 12$) and the special tooth shape, a considerable reduction in design-related volume flow fluctuation and the associated pressure pulsation is achieved.

The gland bearings located on both sides of the gearing carry the journals in heavyduty multicomponent plane bearing bushes and contain additionally those sealing elements which serve for the pressure field sealing to compensate the axial clearance.

Note

1. External loads

External forces acting on the drive shaft end have an influence on the operation of the bearing glands. Radial and axial forces are not permissible. An end bearing must be used for the purpose of absorbing external forces.

2. Direction of rotation

Regarding the direction of rotation basically the following applies provided the view is directed toward the drive shaft end:

Drive shaft end rotating clockwise:

Flow direction from left to right.

Drive shaft end rotating anticlockwise:

Flow direction from right to left.

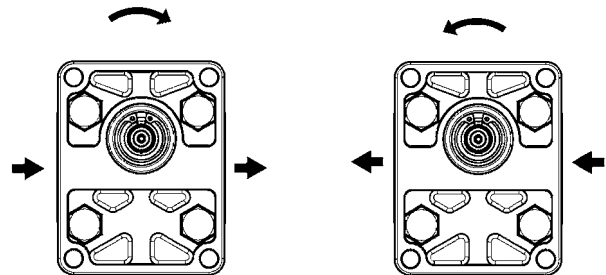

Materials

Housing	Aluminium
Bearing	double-gland bearing with multicomponent plain bearing bushes
Shafts and gear wheels	surface hardened and ground case hardened steel acc. to DIN 17210
Seals	NBR (FKM on request)

Characteristics

Mounting	flange mounting
Pipe connection	threaded connection
Direction of rotation	clockwise or anticlockwise
Fitting position	optional
Ambient temperature	$\vartheta_{u \min}$ = - 20 °C $\vartheta_{u \max}$ = 60 °C
Working pressure Inlet port	$p_{e \min}$ = - 0.3 bar (vacuum)
Working pressure Short time	$p_{e \max}$ = 2.5 bar
Working pressure Outlet port	$p_{e \max}$ see technical data
Fluid temperature	$\vartheta_{m \max}$ 85 °C
Viscosity	ν_{\min} = 10 mm ² /s ν_{\max} = 1400 mm ² /s
Recommended oil cleanliness	class 19/16 acc. to ISO/DIS 4406 ⇨ class 10 acc. to NAS 1638
Recommended filtration	filter with filtration quotient $\beta_{20} \geq 75$ for ... 280 bar $\beta_{25} \geq 75$ for ... 100 bar
Recommended viscosity range	ν = 12 ... 90 mm ² /s
Discharge flow	see chart page 5
Input power	see chart page 5
Hydraulic fluids	mineral oil acc. to DIN 51524 bio-oils of type „HEES“ can be used up to 70 °C, max. pressure must be reduced minus 20 % (use only on request)

Technical Data

Nominal size	geom. displacement	max. pressure	Nominal pressure	Continuous working pressure	Speed	
	V_g cm ³ /rev	p_{max} bar	p_N bar	p_D bar	n_{max} rpm	n_{min} rpm
1	1.4	280	260	220	4000	700
2	1.9	280	260	220	4000	700
3	3.1	260	250	210	4000	700
4	4.4	260	250	210	4000	700
6	6.1	260	250	210	3000	700
8	7.9	200	180	160	3000	700

Maximum pressure = pressure peak
 Nominal pressure $p_N < 6 s = 50\% ED$
 See time/pressure chart
 max. permissible working cycles: 30 / min
 Pressures as specified are applicable to $v \geq 30 \text{ mm}^2/s$

Time / pressure chart

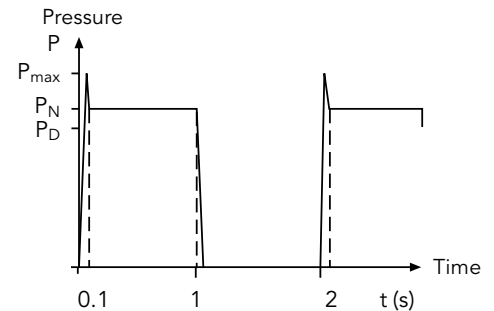

Calculation Formulas for Hydraulic Pumps

Characteristic data, formula signs, units

- | | | |
|--------------------------------|--------------|----------------------|
| 1. Discharge flow / input flow | Q | l/min |
| 2. Pump / motor displacement | V_g | cm ³ /rev |
| 3. Pressure | p | bar |
| 4. Speed | n | rpm |
| 5. Torque | M | Nm |
| 6. Power | P | kW |
| 7. Total efficiency | η_{tot} | — |
| 8. Volumetric efficiency | η_{vol} | — |
| 9. Hydr./mech. efficiency | η_{hm} | — |
| 10. Flow velocity | v | m/s |
| 11. Pipe diameter | d | mm |

General

$$Q_{th} = V_g \cdot n, \quad \eta_{tot} = \eta_{vol} \cdot \eta_{hm}$$

$$M = 9549 \cdot \frac{P}{n}, \quad v = 21.22 \cdot \frac{Q}{d^2}$$

Approximate values for KRACHT products in the nominal working point

KP0	η_{tot}	η_{vol}
1 to 4	≈ 0.75	≈ 0.85
6 to 8	≈ 0.90	≈ 0.90

Characteristic data for:	Volumetric flow	Discharge flow $Q = \frac{V_g \cdot n \cdot \eta_{vol}}{10^3} \left[\frac{l}{min} \right]$
	Torque	Drive torque $M = \frac{p \cdot V_g}{20 \cdot \pi \cdot \eta_{hm}} \text{ [Nm]}$
	Power	Input power $P = \frac{p \cdot Q}{600 \cdot \eta_{tot}} \text{ [kW]}$

Discharge Flow and Required Input Power

Discharge flow at n = 1495 rpm

Nominal size	Discharge flow Q in l/min at 34 mm ² /s						
	Pressure p in bar						
	20	60	100	140	180	220	260
1	2.00	1.95	1.90	1.86	1.82	1.78	1.73
2	2.80	2.70	2.65	2.60	2.55	2.50	2.40
3	4.70	4.65	4.60	4.55	4.50	4.45	–
4	6.30	6.25	6.20	6.15	6.10	6.05	–
6	9.00	8.95	8.90	8.85	8.80	–	–
8	11.75	11.60	11.50	11.45	11.40	–	–

Required input power at n = 1495 rpm

Nominal size	Pressure p in bar						
	20	60	100	140	180	220	260
1	0.14	0.32	0.50	0.68	0.86	1.05	1.23
2	0.17	0.42	0.67	0.92	1.17	1.42	1.66
3	0.25	0.57	0.91	1.30	1.60	2.00	–
4	0.30	0.75	1.20	1.60	2.05	2.50	–
6	0.40	1.05	1.70	2.30	2.95	–	–
8	0.50	1.30	2.10	3.05	3.90	–	–

K-Flange, Tapered Shaft End

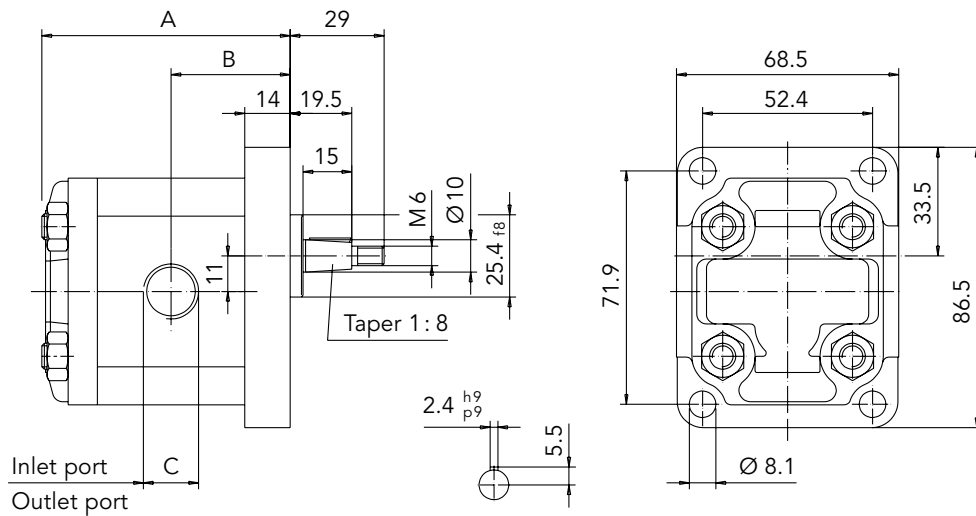

Ordering example:

KP 0/1 K10S M0A 8ML1

The direction of rotation as represented is clockwise
In case of anticlockwise rotation the inlet and outlet ports are opposite

Shaft end: Taper 1:8

Nominal displacement	1	2	3	4	6	8
A	68.6	68.6	68.6	75.3	86.0	86.0
B	33.4	33.4	33.4	36.7	42.0	42.0
C	3/8" BSP			1/2" BSP		
Weight in kg	0.9	0.95	0.95	1.05	1.2	1.2

Bell Housing

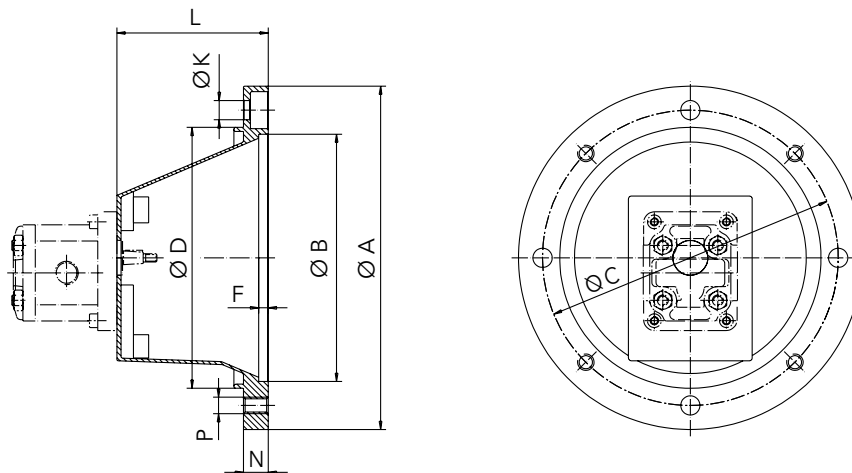

Bell housing with ventilation or leakage hole on request

Motor size	A	B	C	D	F	K	L	N	P	Bell housing Weight in kg	Coupling size
71	160	110	130	110	7	9	70	13	M8	0.5	RA19 -K16/10-Z25/14
80	200	130	165	145	7	11	90	16	M10	0.8	RA19 -K25/10-Z25/19
90	200	130	165	145	7	11	90	16	M10	0.8	RA19/24-K16/10-Z25/24
100/112	250	180	215	190	7	14	110	18	M12	2.0	RA24/28-K16/10-Z50/28

Couplings

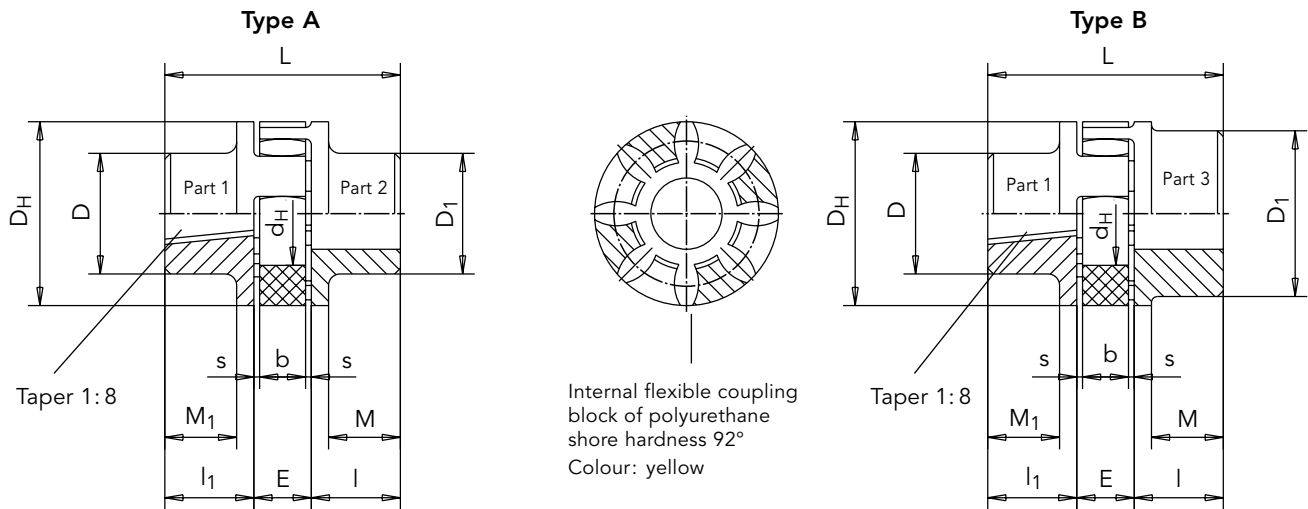

Coupling size

Length of the coupling hub and the hub bore pump sided

Length of the coupling hub and the hub bore motor sided
Straight hub bore

Ordering example:

RA 19 - K 16/10 - Z 25/14

	Coupling size	Weight kg	Moment of inertia kgm ²	Rough bore		Finished bore				Dimensions								Ordering code				
				Part 2	Part 3	min. Part 2	min. Part 3	max. Part 2	max. Part 3	l	l ₁	E	s	b	L	M	M ₁		D _H	D	D ₁	d _H
Type A	19	0.12	0.00003	-	-	6	-	19	-	25	17	16	2	12	58	20	10	40	32	-	18	RA 19-K16/10-Z 25/14
										25												RA 19-K25/10-Z 25/19
Type B	19/24	0.13	0.0004	-	18	-	19	-	24	25	17	16	2	12	58	20	10	41	32	41	18	RA 19/24-K16/10-Z 25/24
	24/28	0.22	0.0001	-	20	-	22	-	28	50	17	18	2	14	85	-	10	55	23	55	27	RA 24/28-K16/10-Z 50/28

Working temperature: - 40°C to + 90°C (short time temperature peaks up to + 120°C are permissible)

RA: Hub material Al

Weights as well as moments of inertia relate to the max. bore dia. after final machining – but without key-way

Bore finish acc. to ISO-fit class H7; key-ways acc. to DIN 6885 / part 1

Motor-Pump Assemblies

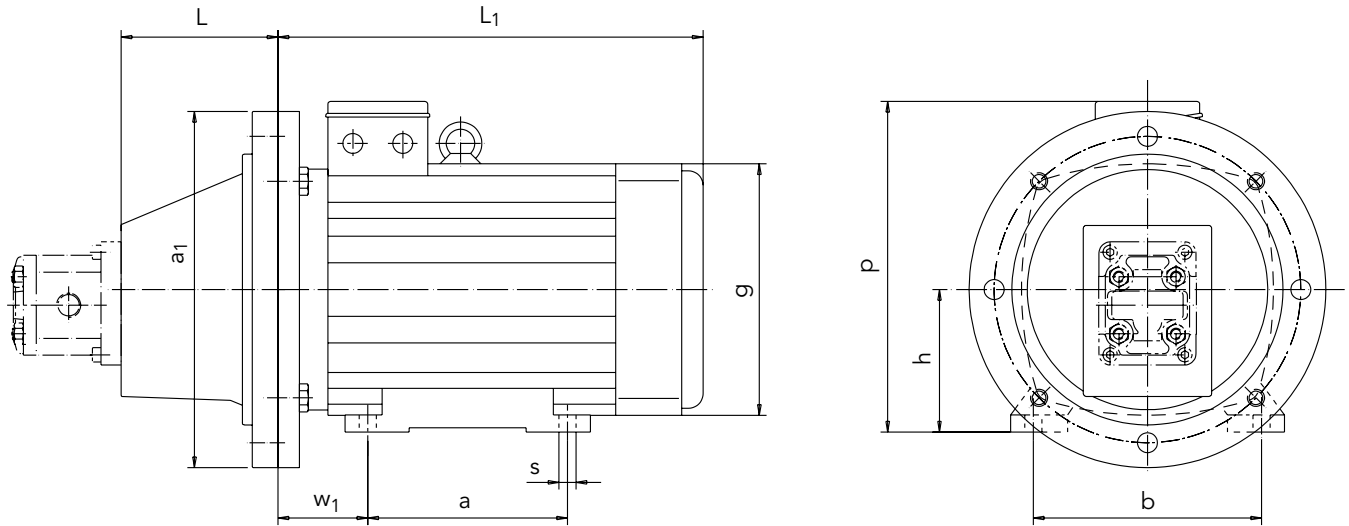

Nominal size	Motor 4-pole		Bell housing	Coupling size		Weight	
	Power kW	Speed rpm				Motor 4-pole kg	Bell housing kg
71 M4A	0.25	1390	PT 160-A-025.4-70	RA 19	- K16/10 - Z25/14	7	0.6
71 M4B	0.37	1390				8	
80 M4A	0.55	1400	PT 200-A-025.4-90	RA 19	- K25/10 - Z25/19	10	0.9
80 M4B	0.75	1400				11	
90 S4A	1.1	1410	PT 200-A-025.4-90	RA 19/24	- K16/10 - Z25/24	13	1.0
90 L4A	1.5	1420				15	
100 L4A	2.2	1420	PT 250-A-025.4-110	RA 24/28	- K16/10 - Z50/28	21	1.7
100 L4B	3	1430				24	
112 M4B	4	1440				31	

Nominal size	Dimensions									
	L	a ₁	a	b	g	h	L ₁	p	s	w ₁
71	70	160	90	125	138	71	223	182	7	45
80	90	200	100	125	158	80	244	199	10	50
90 S	90	200	100	140	193	90	267	218	10	56
90 L	90	200	125	140	193	90	267	218	10	56
100	110	250	140	160	217	100	277	237	12	63
112	110	250	140	190	232	112	308	256	12	70

Motor frame sizes are based on Schäfer. Other manufactures motors can be supplied on request as IM B 35.

Notes

I Gear Pumps

Low and high-pressure gear pumps for lubricating oil, hydraulic, process and test bench applications, fuel and metering systems.



I Flow Measurement

Gear, turbine and screw type flow meters and electronics for volume and flow, metering and consumption in the chemical industry, hydraulic, process and test bench technology.



I Hydraulics

Single and multistage high-pressure gear pumps, gear motors and valves for construction machinery, municipal vehicles, agricultural vehicles, special vehicles and truck bodies.



I Valves

Cetop valves for all requirements stationary and mobile applications. Pressure, switching and stop valves with pipe connection for high flow rates. Special valves.



KRACHT®

KRACHT GmbH · Gewerbestraße 20 · 58791 Werdohl, Germany
 Phone +49 2392.935 0 · Fax +49 2392.935 209
 E-Mail info@kracht.eu · Web www.kracht.eu