

# KRACHT®

- | Gear Pumps
- | Flow Measurement
- | Hydraulics
- | Valves

## High-Pressure Gear Motors **KM 5**

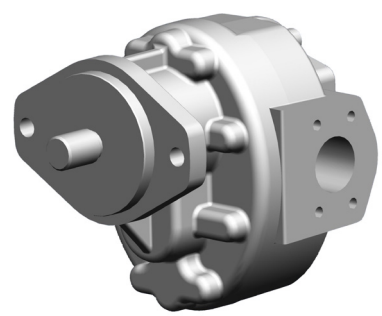



## Construction

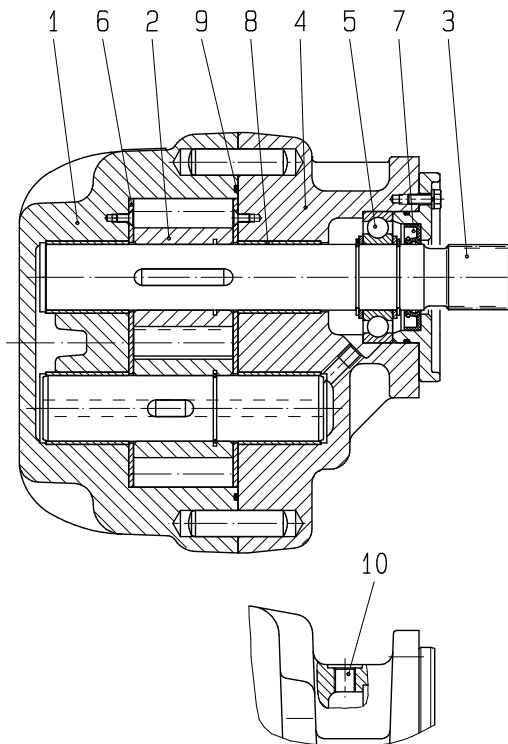

- 1 Housing
- 2 Gearing
- 3 Drive shaft end
- 4 Flange cover
- 5 Rolling bearing
- 6 Sliding plates
- 7 Rotary shaft lip-type seal
- 8 Plain bearing
- 9 Sealing of the housing
- 10 Drain port

## Description

KM series high pressure gear motors are mainly used in oil-hydraulic plants. They are suitable both for hydraulic fluids as well as mineral oil bases (DIN 51524/25) and engine oils (DIN 51511). The housing components are made from high-grade cast iron, the shaft and gears from hardened and ground case-hardening steel. The shafts are supported in multi-layer bearings that have excellent antifriction properties. The seals in the drive shaft ends are made using solely NBR or FKM shaft seals. An outboard bearing is placed on the shaft end to handle radial and axial forces. The use of fine-meshed filters significantly increases the gear pump service life. Careful maintenance is the prerequisite.

## Technical Notes:

### 1. External loads

The robust design facilitates handling external radial forces, depending on the size and direction of application.

### 2. Direction of rotation

Regarding the direction of rotation basically the following applies provided the view is directed toward the drive shaft end:

- Drive shaft end rotating clockwise: Oil flow from left to right
- Drive shaft end rotating anticlockwise: Oil flow from right to left

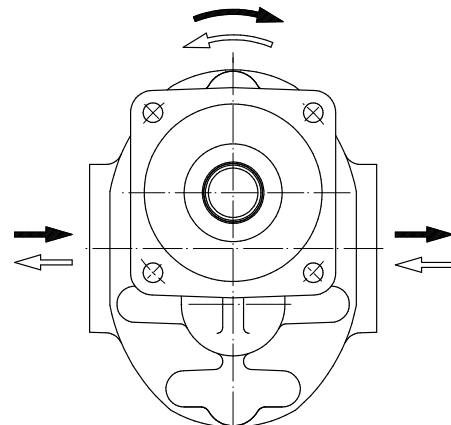

## General Characteristics

Fixing type	Flange type
Pipe connection	Flange; Dimensions page 8
Drive shafts	Dimensions page 8
Direction of rotation	clockwise or anticlockwise
Weight	chart page 7
Mounting position	optional
Ambient temperature	$\vartheta_{u \min} = -20\text{ °C}$ $\vartheta_{u \max} = +60\text{ °C}$

## Working Characteristics

Working pressure	
Inlet port	$p_{\max}$ = please see technical data
Outlet port	$p_{\max}$ = 40 bar
Leakage oil back pressure	at 1000 1/min = 4.5 bar at 1800 1/min = 2.5 bar
Pressure fluid temperature	$\vartheta_{m \min} = -20\text{ °C}$ $\vartheta_{m \max} = +80\text{ °C}$ for NBR Lip-type shaft seal $+120\text{ °C}$ for FKM Lip-type shaft seal
Viscosity	$v_{\min} = 13\text{ mm}^2/\text{s}$ $v_{\max} = 600\text{ mm}^2/\text{s}$
Recommended viscosity range	$v = 16 \dots 90\text{ mm}^2/\text{s}$
Absorption capacity	chart page 5
Output power	chart page 5
Filter	Filter with filtration quotient $\beta_{60} \geq 75$
Pressure fluids	Mineral oil based on DIN 51524/25 Motor oil based on DIN 51511 flameproof pressure fluids on request

## Accessories

Straight flange connection, hole pattern based on SAE standard.

## Calculation Formulas for Hydropumps

### Characteristics, formula signs, units

1 Discharge/displacement flow	Q	l/min
2 geom. discharge/displ. flow	$V_g$	$\text{cm}^3/\text{r}$
3 Pressure	p	bar
4 Speed	n	1/min
5 Torque	M	Nm
6 Power	P	kW
7 Total efficiency	$\eta_{\text{tot}}$	-
8 Volumetric efficiency	$\eta_{\text{vol}}$	-
9 hydr./mech. efficiency	$\eta_{\text{hm}}$	-
10 Flow velocity	v	m/s
11 Piping diameter	d	mm

### General

$$Q_{\text{th}} = V_g \cdot n \cdot \eta_{\text{tot}} = \eta_{\text{vol}} \cdot \eta_{\text{hm}}$$

$$M = 9549 \cdot \frac{P}{n} \cdot v = 21.22 \cdot \frac{Q}{d^2}$$

Parameters for:	Volume flow	Discharge flow $Q = \frac{V_g \cdot n \cdot \eta_{\text{vol}}}{10^3} \left[ \frac{\text{l}}{\text{min}} \right]$
	Torque	Drive torque $M = \frac{p \cdot V_g}{20 \cdot \pi \cdot \eta_{\text{hm}}} \text{ [Nm]}$
	Performance	Input power $P = \frac{p \cdot Q}{600 \cdot \eta_{\text{tot}}} \text{ [kW]}$

Parameters for:	Volume flow	Absorption capacity $Q = \frac{V_g \cdot n}{10^3 \cdot \eta_{\text{vol}}} \left[ \frac{\text{l}}{\text{min}} \right]$
	Torque	Drive torque $M = \frac{\Delta p \cdot V_g \cdot \eta_{\text{hm}}}{20 \cdot \pi} \text{ [Nm]}$
	Performance	Input power $P = \frac{\Delta p \cdot Q_1 \cdot \eta_{\text{tot}}}{600} \text{ [kW]}$

## Displacement / Nominal Size

Displacement Nominal Size	geom. displace- ment $V_g$ cm <sup>3</sup> /r	Working pressure $p_b$ bar	Peak pressure $p_{max}$ bar	Speed range 1/min		Permitted torques in N middle at shaft end (n = 1500 1/min)		Mass inertia torque Shaft end J kg m <sup>2</sup>
				$n_{min}$	$n_{max}$	axial	radial	
219*	215	100	120	800	2000			4.90
250	245	100	120	800	1800	400	1500	5.87
300	293	80	120	800	1500			6.50

\* on request

## Performance data

### High Pressure Gear Motor KM5/219

Delta p	at n = 750 1/min			at n = 1000 1/min			at n = 1500 1/min		
	Q [l/min]	Torque	Power	Q	Torque	Power	Q	Torque	Power
		[Nm]	[kW]	[l/min]	[Nm]	[kW]	[l/min]	[Nm]	[kW]
25	177.2	79	6.2	233.7	77	8.1	346.8	76	12.0
50	179.2	157	12.4	236.3	154	16.1	350.5	152	23.9
75	181.2	236	18.5	238.9	231	24.2	354.4	228	35.9
100	183.2	315	24.7	241.6	308	32.3	358.3	305	47.8

### High Pressure Gear Motor KM5/250

Delta p	at n = 750 1/min			at n = 1000 1/min			at n = 1500 1/min		
	Q [l/min]	Torque	Power	Q	Torque	Power	Q	Torque	Power
		[Nm]	[kW]	[l/min]	[Nm]	[kW]	[l/min]	[Nm]	[kW]
25	199.7	90	7.0	263.4	88	9.2	391.0	87	13.6
50	201.9	179	14.1	266.3	175	18.4	395.2	174	27.3
75	204.2	269	21.1	269.2	263	27.6	399.5	260	40.9
100	206.5	359	28.2	272.2	351	36.8	403.8	347	54.5

### High Pressure Gear Motor KM5/300

Delta p	at n = 750 1/min			at n = 1000 1/min			at n = 1500 1/min		
	Q [l/min]	Torque-	Power	Q	Torque	Power	Q	Torque	Power
		[Nm]	[kW]	[l/min]	[Nm]	[kW]	[l/min]	[Nm]	[kW]
25	236.3	108	8.5	311.7	106	11.1	462.6	105	16.5
50	238.9	217	17.0	315.1	212	22.2	467.6	210	33.0
75	241.5	325	25.5	318.5	318	33.3	472.6	315	49.4
80	244.2	347	27.2	322.0	339	35.6	477.7	336	52.7

## Type Key

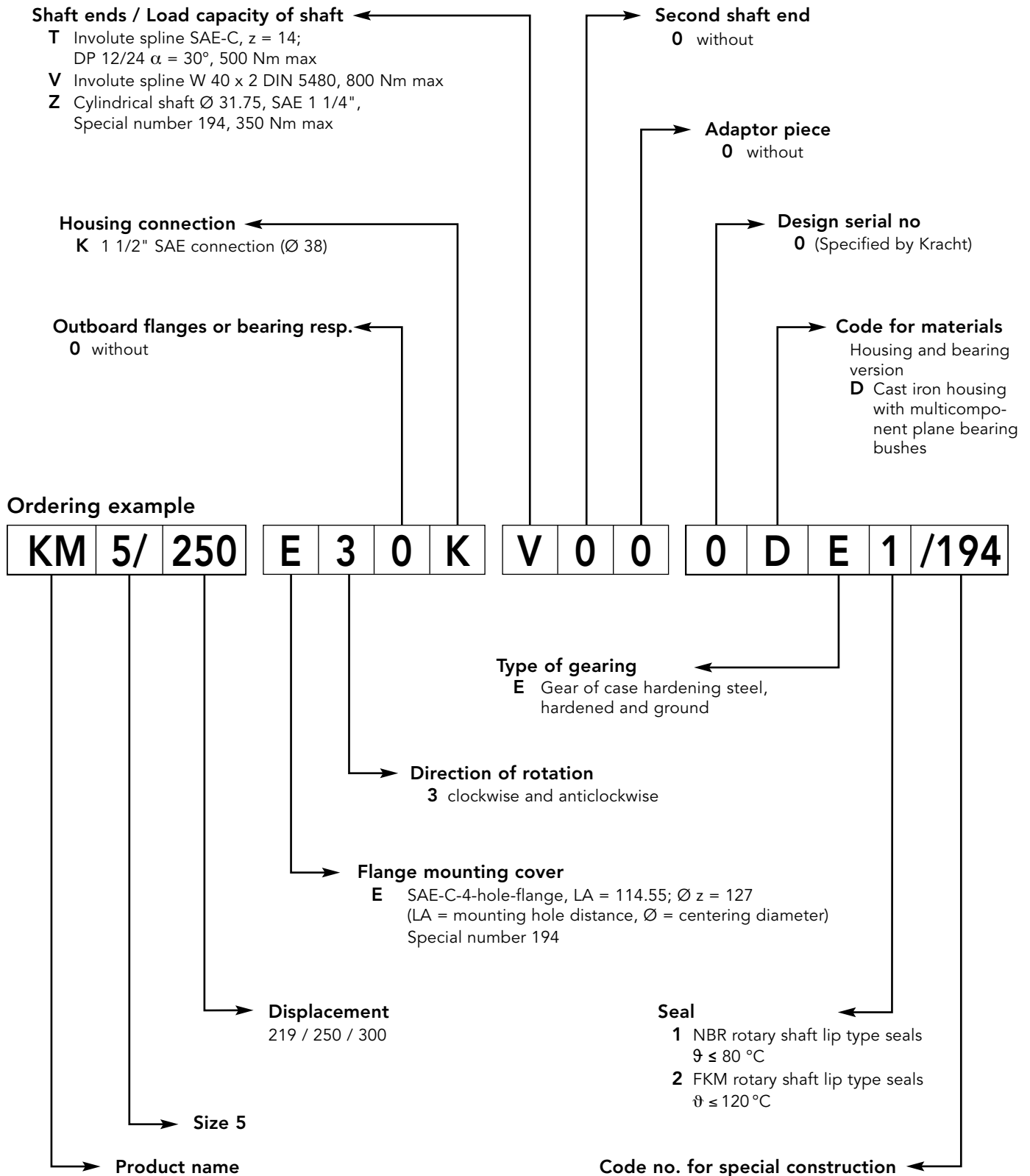

## Dimensions

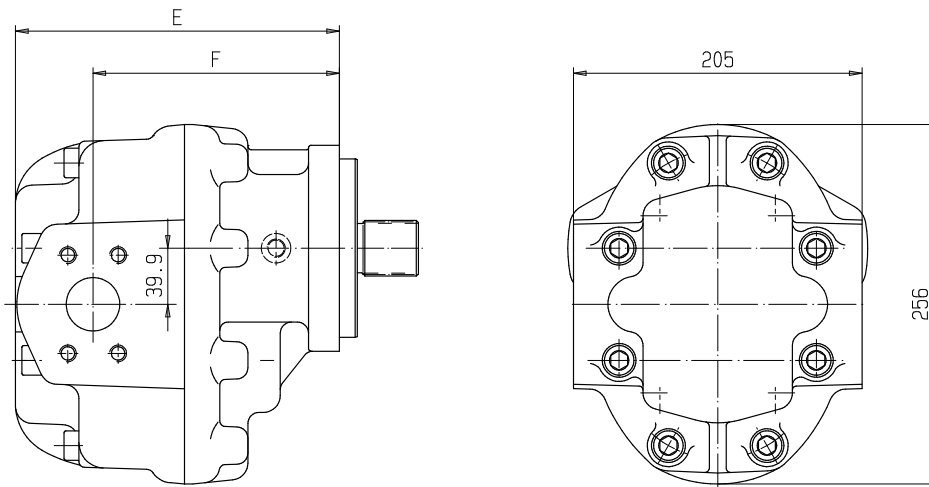

Displacement Nominal Size	E	F	Weight in kg
219	235.5	180.5	47
250	243.0	188.0	49
300	255.0	200.0	53

## Flange Type

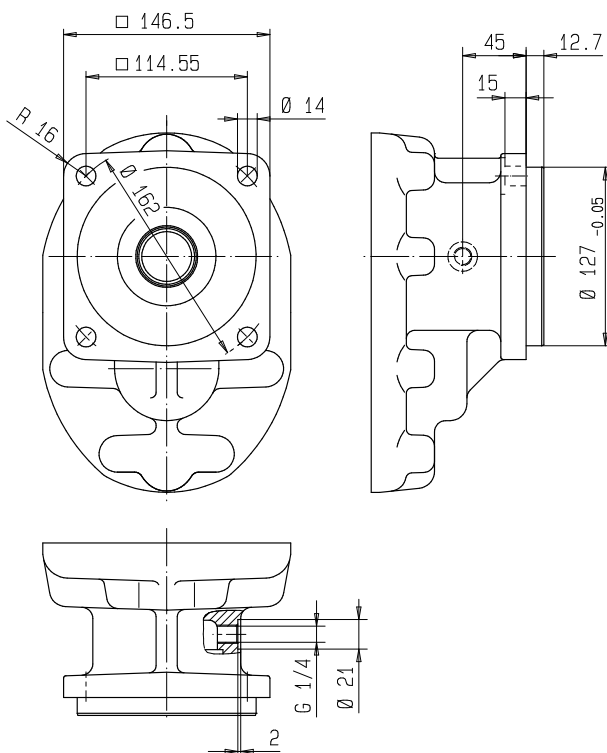

SAE-C-4 hole flange E, ... /194  
with leakage oil connection  
LA = 114.55;  $\varnothing z = 127$

## Connections

### Housing connection 1 1/2" SAE connection (Ø 38)

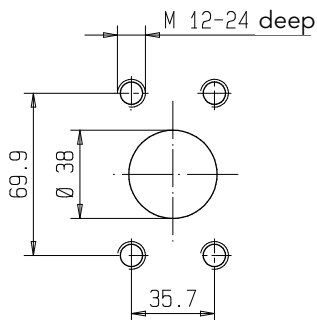

## Shaft Ends

Shaft end T  
Spline profile SAE-C  
Z = 14; DP 12/24,  $\alpha = 30^\circ$

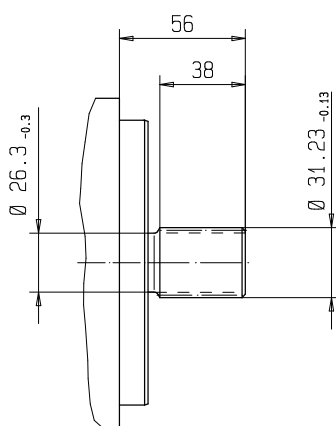

Shaft end V  
Spline profile W 40 x 2, DIN 5480

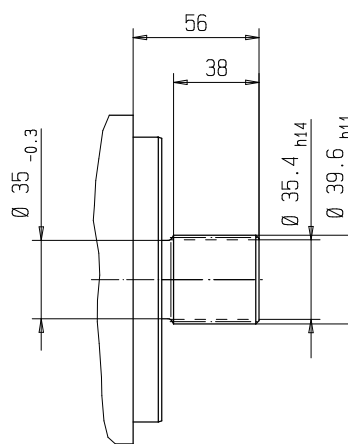

Shaft end Z  
Special number 194  
Cylindrical shaft SAE 1 1/4" (Ø 31.75)

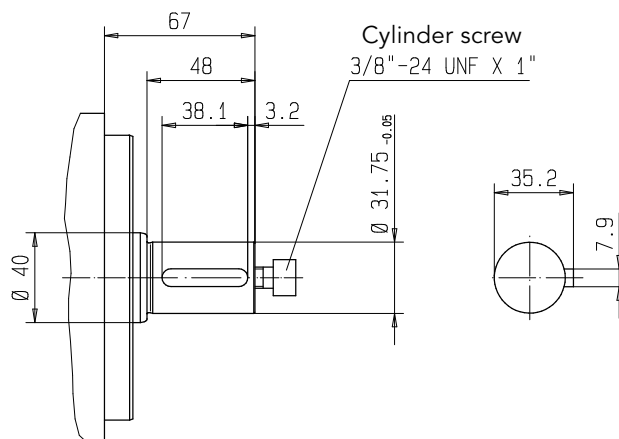



## Note

---

## I Gear Pumps

Low and high-pressure gear pumps for lubricating oil, hydraulic, process and test bench applications, fuel and metering systems.



## I Flow Measurement

Gear, turbine and screw type flow meters and electronics for volume and flow, metering and consumption in the chemical industry, hydraulic, process and test bench technology.



## I Hydraulics

Single and multistage high-pressure gear pumps, gear motors and valves for construction machinery, municipal vehicles, agricultural vehicles, special vehicles and truck bodies.



## I Valves

Cetop valves for all requirements stationary and mobile applications. Pressure, switching and stop valves with pipe connection for high flow rates. Special valves.



# KRACHT®

KRACHT GmbH · Gewerbestraße 20 · 58791 Werdohl, Germany  
 Phone +49 2392.935 0 · Fax +49 2392.935 209  
 E-Mail [info@kracht.eu](mailto:info@kracht.eu) · Web [www.kracht.eu](http://www.kracht.eu)