

KRACHT®

- | Gear Pumps
- | Flow Measurement
- | Hydraulics
- | Valves

Gear Pumps
KF 32 ... 112
with Universal Valve

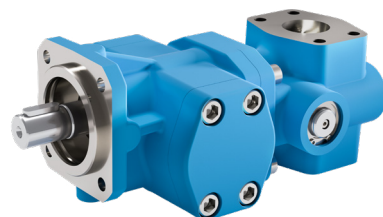

Description

Transfer Gear Pumps KF are used for pumping a wide variety of fluids.

Transfer Gear Pumps KF are distinguished especially by their wide range of variants which are assembled as required on the modular principle and also permit subsequent upgrade.

The pumps are also suitable for media with low lubricating properties. The mounting position can be chosen arbitrarily. The KF 32...112 with universal valve also promotes with varying direction of rotation of the drive shaft to the same outlet port.

Principle-partly outlet port and inlet port stays the same with any drive direction.

The pump housing are in gray cast iron and in spheroidal cast iron available. The valve housing is made of spheroidal cast iron.

The gear units are manufactured from high-strength case-hardening steel, hardened and mounted in special multi-compound plain bearing bushes.

The standard drive shaft is sealed by rotary shaft lip-type seal. All pump sizes incorporate helical tooth system. This feature combined with special gear geometry, results in low noise levels and reduced pressure pulsation.

Operating Notes

- The fluids should ensure a certain minimum lubricating properties, should not contain solids and should be chemically compatible.
- Avoid dry operation.
- In order to prevent excessive overpressure, a safety valve is provided in the system.
- To drain off a partial discharge flow over a prolonged period, a separate pressure relief valve with return line must be inserted in the reservoir.

Construction

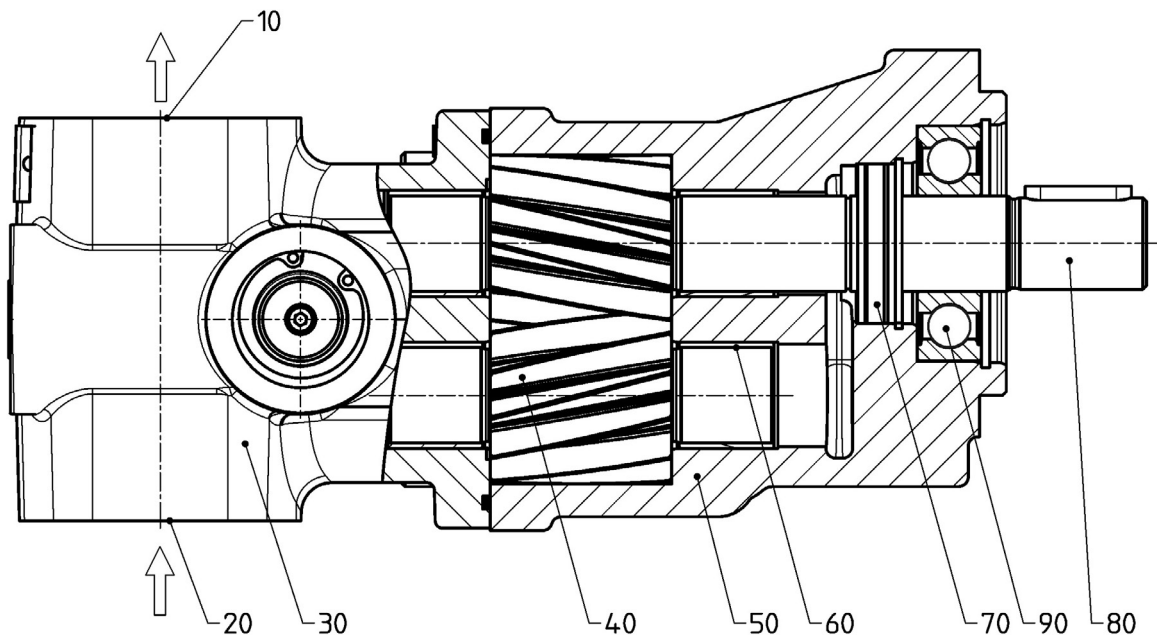

10 Outlet port	40 Gear	70 Shaft seal
20 Inlet port	50 Pump housing	80 Drive shaft end
30 Universal valve	60 Bearing bush	90 Outboard bearing (optional)

Materials

Housing	EN-GJL-250 (GG 25) or EN-GJS-400-15 (GGG 40)
Valve	EN-GJS-400-15 (GGG 40)
Gear	Steel 1.7139
Bearing bush	DU (multi-compound plain bearings P 10, DP 4) Bearings free of nonferrous metal on request
Shaft seal	NBR, FKM, low temperature FKM (other sealing materials on request)
O-ring	NBR, FKM, low temperature FKM (other sealing materials on request)

Characteristics

Nominal sizes 32...112 cm ³	V _G	32 / 40 / 50 / 63 / 80 / 100 / 112
Mounting position		arbitrary
Direction of rotation		bidirectional
Fixing type		flange (DIN ISO 3019)
Pipe connection		1 1/2" SAE flange = 32...80 2" SAE flange = 100/112
Drive shaft end		ISO R 775 short cylindrical
Working pressure Inlet port (Version BABSL)	p _{e min} p _{e max}	= - 0.4 bar (- 0.6 bar short term during startup status) = 2 bar
Outlet port	p _{n max}	= 25 bar
Speed	n _{min} n _{max} n _{max} n _{max}	= 200 1/min = 3000 1/min (at nominal size 32/40/50) = 2200 1/min (at nominal size 63/80) = 2200 1/min (at nominal size 100/112)
Viscosity (dependent on pressure and speed)	v _{min} v _{max}	= 12 mm ² /s = 20000 mm ² /s
Fluid temperature	ϑ _{m min} ϑ _{m max}	= - 30 °C = 150 °C
Ambient temperature Standard version	ϑ _{u min} ϑ _{u max}	= - 20 °C = 60 °C
Version 31	ϑ _{u min} ϑ _{u max}	= - 40 °C = 60 °C

Recommended speed

Kinematic viscosity v [mm ² /s]	< 300	300	500	1000	2000	3000	6000	10000	20000	30000
Speed n [1/min]	≥ 1450	1250	1000	750	600	500	400	300	200	100

Type Key

Ordering example

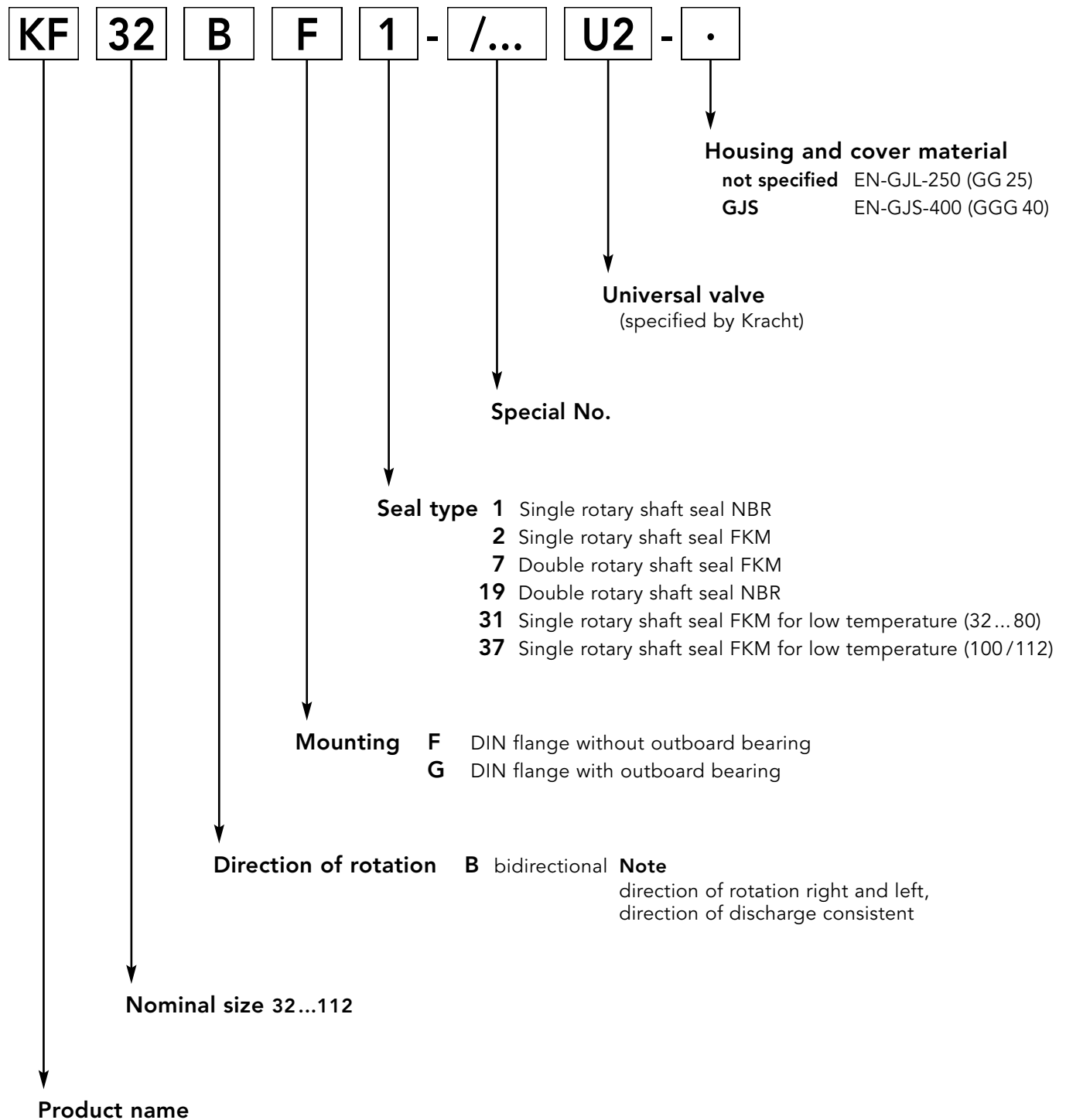

Dimensions Nominal Sizes 32... 80 (in mm)

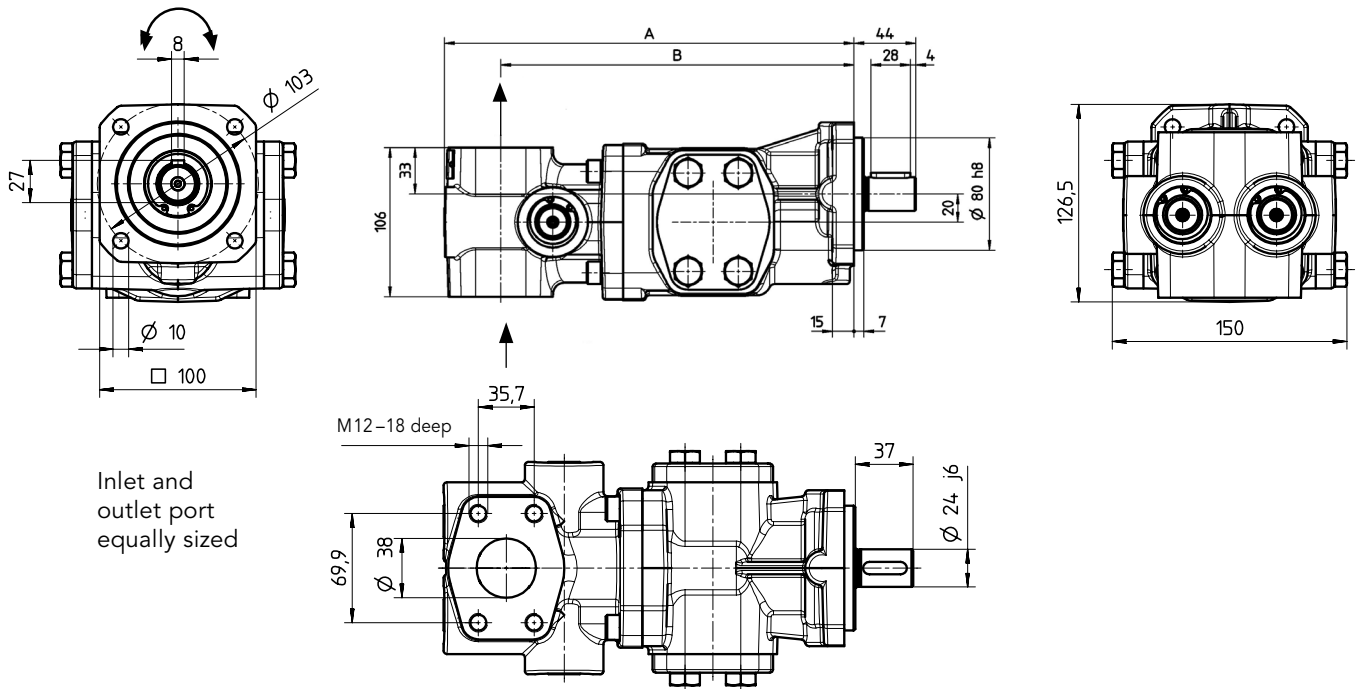

Nominal displacement	A	B	Weight in kg
32			
40	256	216	15.5
50			
63	291	251	17.5
80			

Dimensions Nominal Sizes 100/112 (in mm)

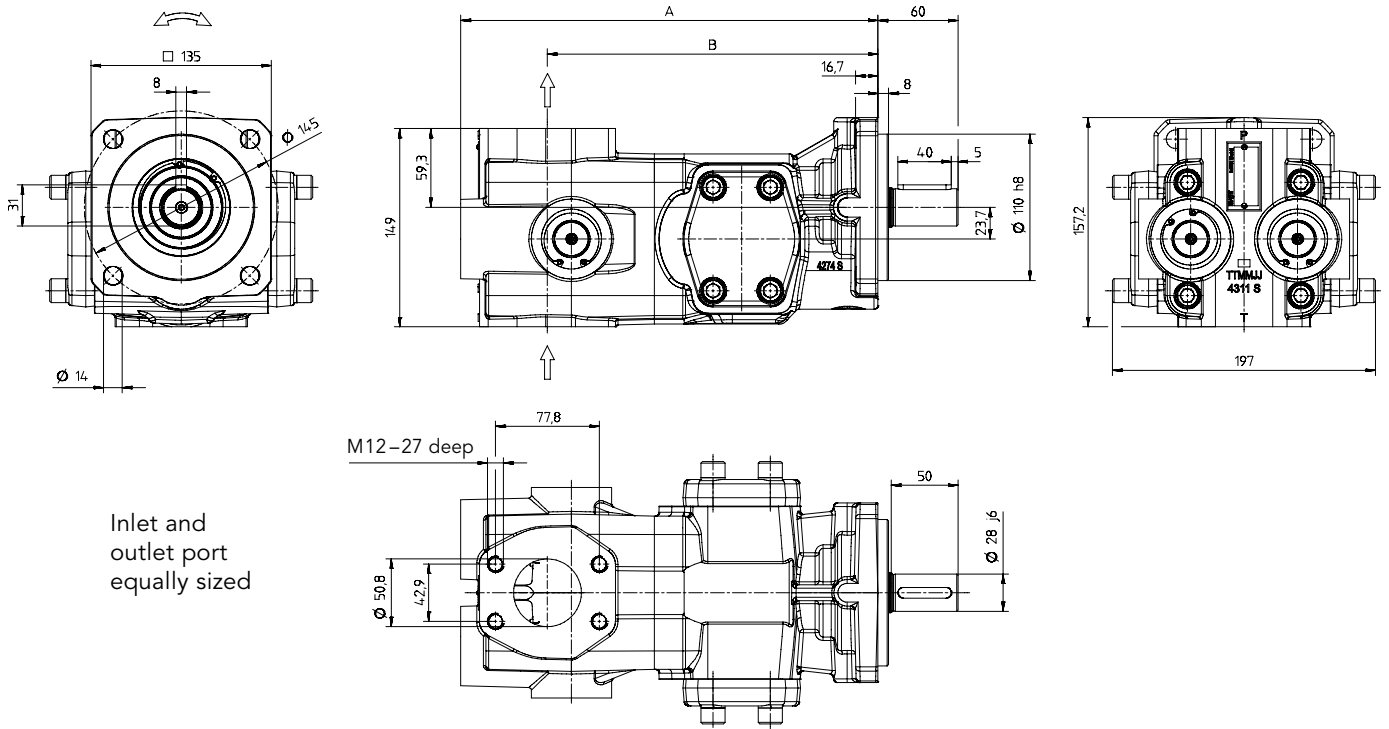

Nominal displacement	A	B	Weight in kg
100	312.5	247.5	21.6
112	312.5	247.5	21.6

I Gear Pumps

Low and high-pressure gear pumps for lubricating oil, hydraulic, process and test bench applications, fuel and metering systems.



I Flow Measurement

Gear, turbine and screw type flow meters and electronics for volume and flow, metering and consumption in the chemical industry, hydraulic, process and test bench technology.



I Hydraulics

Single and multistage high-pressure gear pumps, gear motors and valves for construction machinery, municipal vehicles, agricultural vehicles, special vehicles and truck bodies.



I Valves

Cetop valves for all requirements stationary and mobile applications. Pressure, switching and stop valves with pipe connection for high flow rates. Special valves.



KRACHT®

KRACHT GmbH · Gewerbestraße 20 · 58791 Werdohl, Germany
 Phone +49 2392.935 0 · Fax +49 2392.935 209
 E-Mail info@kracht.eu · Web www.kracht.eu