

KRACHT®

- | Gear Pumps
- | Flow Measurement
- | Hydraulics
- | Valves

Gear Pumps **KF 730 ... 1500**

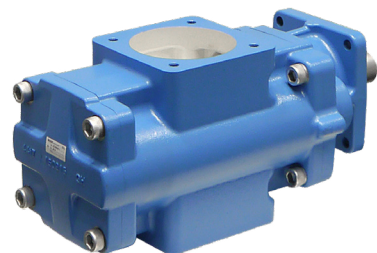

Construction

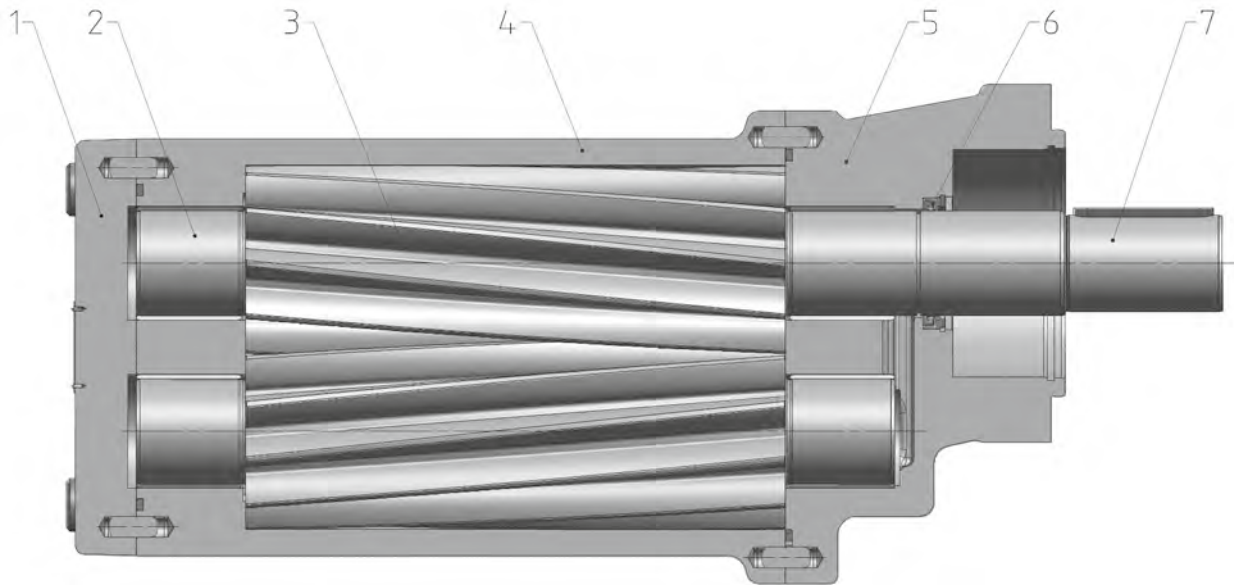

- | | |
|------------------------|----------------|
| 1 End cover | 5 Flange cover |
| 2 Plain bearing bushes | 6 Shaft seal |
| 3 Gear | 7 Shaft end |
| 4 Housing | |

Description

Gear pumps KF are used for pumping a wide variety of fluids. Gear pumps KF are distinguished especially by their wide range of variants which are assembled as required on the modular principle and also permit subsequent upgrade. The standard housing sections are of grey cast iron. The gear units are manufactured from high-strength case-hardening steel, hardened and mounted in special multi-compound plain bearing bushes. The standard drive shaft is sealed by single radial lip-type seal. All pump sizes incorporate helical tooth system. This feature, combined with special gear geometry, results in extremely low noise levels and reduced pressure pulsation.

Working Notes

- The fluids should ensure a certain minimum lubricating properties, should not contain solids and should be chemically compatible.
- Avoid dry operation.
- The pumps may only be operated in the specified direction of rotation, as otherwise the shaft seal will be destroyed.
- In order to prevent excessive overpressure, a safety valve should be provided in the system.

Variants

- Sealing of the drive shaft:
 - Single radial lip-type seal
 - Double radial lip-type seal (Quench)
 - Mechanical seal
- Outboard bearing to take up input drive-side radial load

Accessories

- Connecting flanges
- Couplings
- Bell housing
- Quench tank
- Attenuation elements

Special Design

Various shafts ends and gear units, as well as flange mounted versions, bearing alternatives, multi-stage pump combinations for your special application are available on request.

Our Sales engineers will be pleased to advise you.

Direction of Rotation

The following should be note for direction of rotation:

- when looking at the pump shaft end, the direction of pumping is from left to **right** if the shaft rotates clockwise.
- when looking at the pump shaft end, the direction of pumping is from right to **left** if the shaft rotates counterclockwise.

Without pressure relief valve

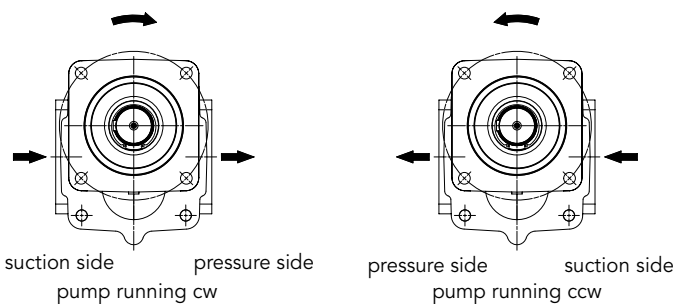

With pressure relief valve

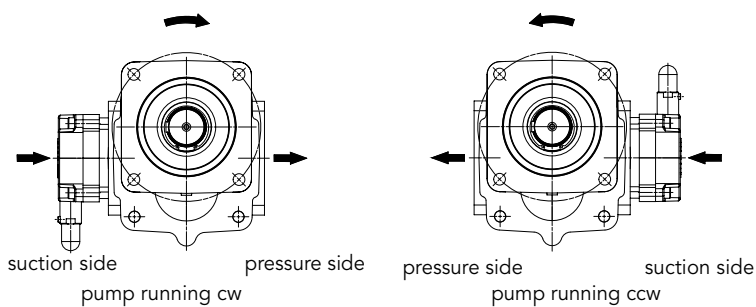

Materials

Housing and cover	EN-GJL-250 (GG 25) EN-GJS-400-15 (GGG 40)
Gear	Steel 1.7139
Plain bearing bushes	DU (multi-layer friction-type bearings P 10, DP 4) Bearings free of nonferrous metal on request
Shaft seals	Single radial lip-type seals: NBR, FKM, PTFE, EPDM Mechanical seal: Metal-impregnated carbon /SiC, FKM, CrNi-Steel
O-ring	NBR, FKM, EPDM, FEP with FKM-core

Characteristics

Nominal sizes	cm ³ /rev	730 / 1000 / 1250 / 1500
Mounting position		KF ... R/L/B ... without Quench optional KF ... R/L/B ... with Quench horizontal, Quench connection above
Direction of rotation		right or left right and left for reciprocal operation (Continuous operation on request)
Flange connection		SAE D 4-hole flange
Housing connection		KF 730 / KF 1000 - flange DN 132 / hole circle 180 KF 1250 / KF 1500 - flange DN 160 / hole circle 210
Drive shaft end		cylindrical Ø 55 mm
Working pressure suction side		see chart working pressure
Working pressure pressure side		see chart working pressure
Speed	n	200 ... 2000 1/min
Recommended speed		The speed of the pump must be chosen in such a way that complete pump filling is guaranteed. This is given if the relative pressure at the pump inlet does not fall below -0.4 bar (-0.6 bar briefly e.g. during cold start).
Viscosity	V _{min} V _{max}	1.4... 12 mm ² /s (see chart permissible temperatures) 20 000 mm ² /s (higher viscosities on request)
Fluid temperature		see chart permissible temperatures
Ambient temperature		see chart permissible temperatures

Permissible Differential Pressure

Bearing	Δp_{max} [bar]		
	≥ 1.4 mm ² /s	≥ 6 mm ² /s	≥ 12 mm ² /s
Multi-layer plain bearing containing lead : DU®, P10	3	12	25 ⁽¹⁾
Multi-layer plain bearing lead-free : DP4			
Plastic plain bearing: Iglidur® G; X; H370	-	6	10

⁽¹⁾ KF 1250 and KF 1500: 20 bar

Working Pressure

Shaft seals standard operation					
	Sealing material	Speed [1/min]	Working pressure		
			suction side p_e [bar] ⁽¹⁾	pressure side p_b [bar]	
Single radial lip-type seal	NBR / FKM	≤ 750	-0.4 ... 5.0	25 ⁽²⁾	
Outboard bearing with single radial lip-type seal		≤ 1000	-0.4 ... 4.0		
Double radial lip-type seal with connection possibility for quench		EPDM	≤ 1500		-0.4 ... 2.5
			≤ 2000		-0.4 ... 1.5
Mechanical seal	PTFE	≤ 2000	-0.4 ... 0.5		
			-0.4 ... 2.0		
	FKM	≤ 2000	-0.4 ... 10.0		

Shaft seals vacuum operation				
	Sealing material	Speed [1/min]	Working pressure	
			suction side p_e [bar]	pressure side p_b [bar]
Double radial lip-type seal for vacuum operation with connection possibility for quench	NBR / FKM / PTFE	≤ 2000	-0.9 ... 0.2	25 ⁽²⁾

⁽¹⁾ short term during start-up status: -0.6 bar

⁽²⁾ KF 1250 and KF 1500: 20 bar

The indicated maximum values are dependent upon the remaining working conditions.
 Note vacuum operation: The tank installation must be above the suction connection.
 Other sealing materials on request.

Permissible Temperatures

Media temperature		Ambient temperature		Sealing material
9m min [°C]	9m max [°C]	9m min [°C]	9m max [°C]	
-20	90	-20	60	NBR
	200			PTFE / FEP with FKM core
	120			EPDM
	150			FKM

Variants Shaft End Seals

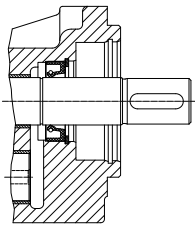

Pump with single radial lip-type seal

Sealing materials:

- NBR = sealing type 1
- FKM = sealing type 2
- PTFE = sealing type 3
- EPDM = sealing type 9
- FKM = sealing type 18

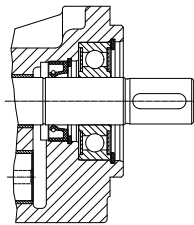

Pump with outboard bearing and single radial lip-type seal

Sealing materials:

- NBR = sealing type 1
- FKM = sealing type 2
- PTFE = sealing type 3
- EPDM = sealing type 9
- FKM = sealing type 18

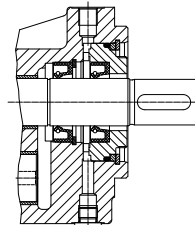

Pump with double radial lip-type seal with connection possibility for quench

Sealing materials:

- NBR = sealing type 19
- FKM = sealing type 7
- PTFE = sealing type 4
- EPDM = sealing type 32

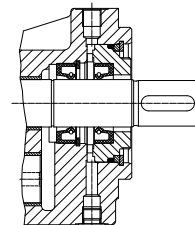

Pump with double radial lip-type seal for vacuum operation with connection possibility for quench

Sealing materials:

- NBR = sealing type 19
- FKM = sealing type 7
- PTFE = sealing type 4
- Special number: 74

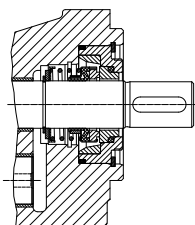

Pump with mechanical seal

Sealing materials:

- FKM = sealing type 40

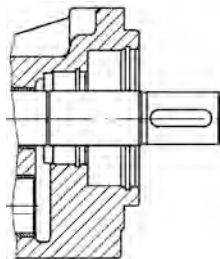

Pump without shaft sealing

Sealing materials:

- FKM (O-ring) = sealing type 30
- NBR (O-ring) = sealing type 36

KF 730 ... 1500 noise optimized for medias with increased air percentage

The noise optimized pumps in the KF series are designed for conveying for medias with increased air content, predominantly for use as lubricating oil pumps in gears. Special measures prevent the otherwise normally increased noise present in auriferous gear oil. The noise levels do not exceed or only barely exceed the measurements with non-auriferous oils. Also, there is no noise spectrum shift to higher, unpleasant frequencies. In applications without auriferous portions in the media, it is not recommended to use this version as it will not bring about noise reduction effects there.

The noise optimized version of the KF pump is marked with the special number **197** at the end of the type key. Pumps with the special number **197** are built as pumps in combination with an electric motor or as mounted pumps. The pump in combination with an electric motor (Fig. 1) does not have an outboard bearing, so it has to be driven via an elastic coupling. The mounted pump (Fig. 2) comes equipped with an outboard bearing to absorb the centrifugal forces such as those which arise when using a flying pinion. Pumps for electric motor drives and mounted pumps are sealed at the shaft end using a lip-type shaft seal.

Fig. 1

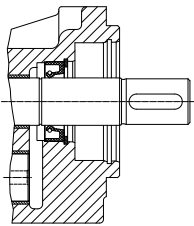

Pump with single radial lip-type seal

Sealing materials:

NBR = sealing type 1

FKM = sealing type 2

Fig. 2

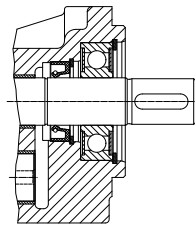

Pump with outboard bearing and single radial lip-type seal

Sealing materials:

NBR = sealing type 1

FKM = sealing type 2

Note

The noise optimized version is also available in a spheroidal cast iron version. Dimensions conformable standard pumps.

Type Key (Ordering example)

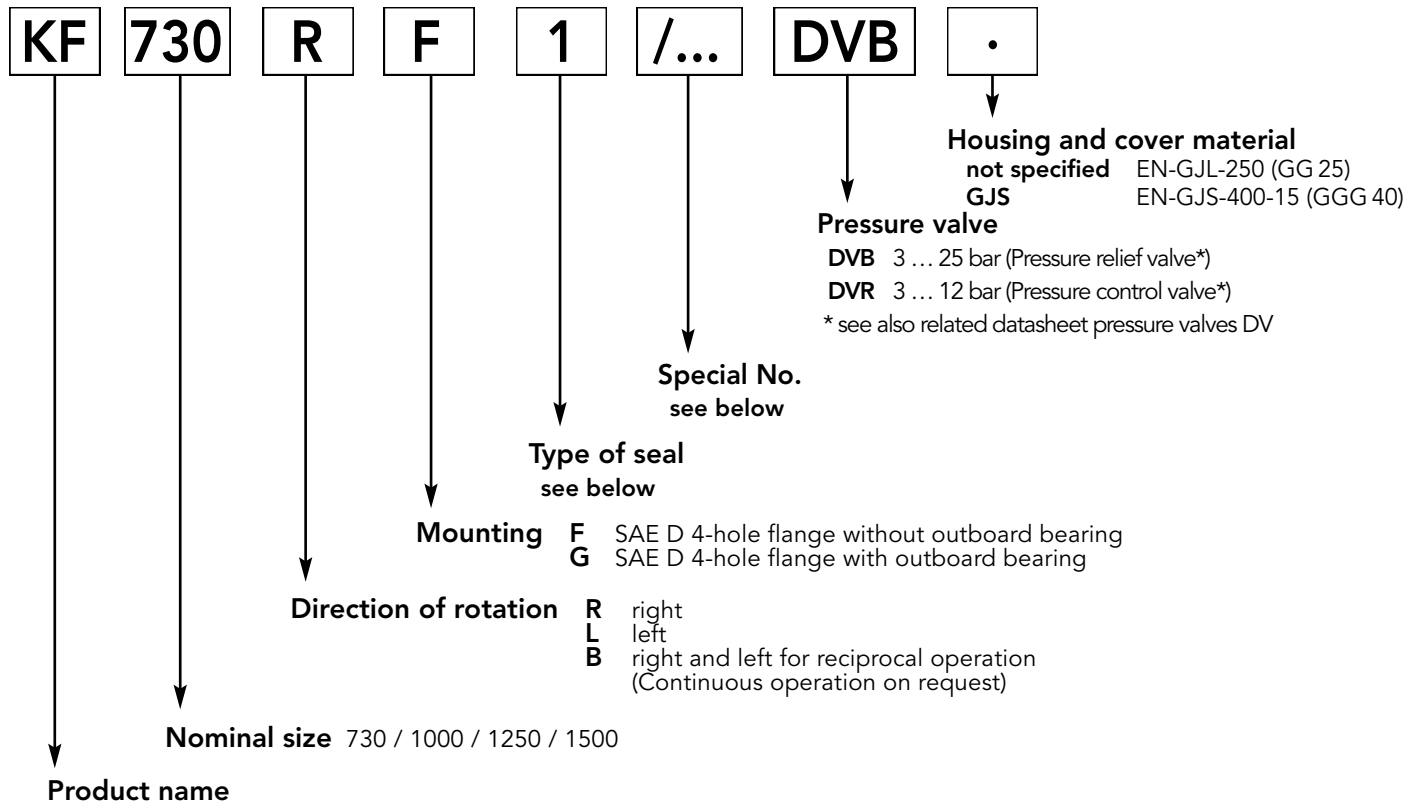

Seal Type

1	Single radial lip-type seal NBR (BABSL)	18	Single radial lip-type seal FKM (BAUMX7)
2	Single radial lip-type seal FKM (BABSL)	19	Double radial lip-type seal NBR (BABSL)
3	Single radial lip-type seal PTFE (HN2390)	30	without shaft seal o-ring FKM
4	Double radial lip-type seal PTFE (HN2390)	32	Double radial lip-type seal EPDM (R02-R) (not resistant to mineral oil)
7	Double radial lip-type seal FKM (BABSL)	36	without shaft seal o-ring NBR
9	Single radial lip-type seal EPDM (R02-R)	40	Mechanical seal with FKM secondary seals (L4) AQ2VFF

Special Numbers

74	Double radial lip-type seal (for vacuum operation) Connection borehole G 1/8 (for Quench)
197	Noise-optimized version for aerated oils ⁽¹⁾

⁽¹⁾ Measures for noise optimisation are only possible for one rotational direction and only effective for aerated oils or vacuum (only in connection with seal versions that are suitable for vacuum operation). Can lead to a reduction of delivery rate.

Technical Data

Nominal size	geom. displacement V_g [cm ³ /rev]	Working pressure p_b [bar]	Maximum pressure (pressure peak) $p_{b \max}$ [bar]	Speed range ⁽¹⁾		Perm. radial force ⁽³⁾ ($n = 1500$ 1/min) F_{radial} [N]	Sound pressure level dB (A)		
				n_{\min} [1/min]	n_{\max} ⁽²⁾ [1/min]		$p_b =$ 5 bar	$p_b =$ 15 bar	$p_b =$ 25 bar
730	713.8	25	30	200	2000	2500	80	81	81
1000	985.7		25				81	83	83
1250	1236.2	25	83				84	86	
1500	1473.0	20	83				85	86 ⁽⁴⁾	

⁽¹⁾ Comply with media-specific properties.

⁽²⁾ Pay attention to the viscosity.

⁽³⁾ Outside forces are only permissible in combination with an outboard bearing. F_{radial} on central shaft end.

⁽⁴⁾ $p_b = 20$ bar

For certain working conditions, the minimum or maximum characteristics should not be used.

For example, the max. working pressure is not permissible in combination with low speed and low viscosity.

In such limit ranges, please consult us.

Sound level measured in dB(A) at 1 m distance

Sound level measured with drive motor,

Installation site:

Works hall, quiet sound level = 40 dB(A)

Pump assembly on rigid fastening angle,

Suction and pressure conduits: Hose

measured with gear oil,

Oil viscosity $\nu = 34$ mm²/s,

Speed $n = 1500$ 1/min.

Discharge Flow / Input Power

		Speed n = 950 1/min																Power consumption P [kW]
		Pressure p _b [bar]				Nominal size				Pressure p _b [bar]								
Discharge Q [l/min]		2	4	6	8	10	15	20	25	2	4	6	8	10	15	20	25	
		662	643	626	609	594	555	520	486	730	4.6	6.9	9.2	11.6	14.0	20.0	26.0	32.0
		921	901	886	864	849	801	760	720	1000	7.4	9.3	13.7	15.9	20.3	27.2	35.4	43.6
		1160	1140	1121	1103	1084	1041	1000	961	1250	8.5	12.6	16.8	20.7	24.9	35.1	45.3	55.6
		1389	1371	1351	1335	1316	1270	1229	-	1500	10.3	15.1	20.0	24.8	29.8	42.0	54.2	-

		Speed n = 1450 1/min																Power consumption P [kW]
		Pressure p _b [bar]				Nominal size				Pressure p _b [bar]								
Discharge Q [l/min]		2	4	6	8	10	15	20	25	2	4	6	8	10	15	20	25	
		1029	1012	995	980	966	930	896	862	730	10.4	14.0	17.6	21.2	24.8	34.0	43.1	52.5
		1413	1399	1383	1367	1351	1314	1273	1236	1000	14.6	19.5	24.5	29.5	34.6	47.9	59.5	71.8
		1783	1765	1750	1735	1720	1682	1644	1609	1250	21.1	26.9	33.2	39.7	45.8	61.3	77.2	92.3
		2130	2116	2101	2087	2072	2034	1998	-	1500	24.3	31.6	39.3	46.9	54.2	73.0	91.7	-

		Speed n = 1150 1/min																Power consumption P [kW]
		Pressure p _b [bar]				Nominal size				Pressure p _b [bar]								
Discharge Q [l/min]		2	4	6	8	10	15	20	25	2	4	6	8	10	15	20	25	
		810	791	774	758	743	705	669	636	730	6.4	9.3	12.2	15.0	17.9	25.2	32.5	39.7
		1119	1100	1084	1064	1047	1005	969	925	1000	8.8	12.7	17.4	20.6	24.6	34.3	45.2	54.3
		1411	1393	1376	1358	1342	1300	1259	1223	1250	12.7	17.6	22.4	27.6	32.3	44.8	57.2	69.4
		1682	1666	1651	1634	1616	1575	1534	-	1500	15.4	20.5	26.5	32.6	38.4	53.2	68.4	-

		Speed n = 1750 1/min																Power consumption P [kW]
		Pressure p _b [bar]				Nominal size				Pressure p _b [bar]								
Discharge Q [l/min]		2	4	6	8	10	15	20	25	2	4	6	8	10	15	20	25	
		1247	1230	1214	1200	1187	1152	1120	1087	730	15.9	20.1	24.4	28.8	33.0	44.1	55.0	66.3
		1711	1697	1682	1667	1653	1620	1582	1547	1000	22.3	28.2	34.2	40.1	46.3	62.4	76.1	91.2
		2150	2135	2124	2111	2097	2062	2029	1995	1250	31.4	38.8	46.4	53.9	61.8	80.9	99.3	117.9
		2568	2556	2543	2531	2519	2488	2457	-	1500	37.4	46.4	55.1	64.0	73.5	96.6	117.4	-

Notes:

- The ratings refer to a mineral oil with a viscosity of 34 mm²/s.
- Margin of error for the flow Q + 2.5% ... -5% of the tabular value.
- For viscosity < 30 mm²/s take a reduction of the rated flow Q into account.
- The output of the drive motor should be selected 20% higher than tabular value P.
- For viscosity > 100 mm²/s, an increase in the required power is necessary, in this case proceed as per description on page 11.
- -3% of discharge flow for the noise-optimized version.

Calculation of input power

Calculation

$$P_{1Pu} = P_{tab} \frac{n}{1450} + f_v \cdot Q$$

P_{1Pu} = pump power consumption [kW]

P_{tab} = power consumption per table [kW] bei 1450 1/min

n = speed (1/min)
dependent on viscosity!
(see speed recommendation)

f_v = viscosity factor $\left[\frac{\text{kW}}{\text{l/min}} \right]$
(see diagram)

Q = discharge flow [l/min] with $Q = \frac{V_g \cdot n}{1000}$

V_g = geometrical displacement [cm³/rev]

Conversion factors

$$1 \text{ bar} \triangleq 14.5 \frac{\text{lb}}{\text{in}^2} = 14.5 \text{ psi}$$

$$1 \frac{\text{l}}{\text{min}} \triangleq 0.220 \frac{\text{gal}}{\text{min}} = [\text{U.K.}]$$

Example: Pump type KF 1500

Viscosity $v = 3000 \text{ mm}^2/\text{s}$

Working pressure $p = 10 \text{ bar}$

at $P_{tab} = 54.2 \text{ kW}$

$n = 500 \text{ 1/min}$

$f_v = 0.017 \frac{\text{kW}}{\text{l/min}}$

$$Q = \frac{1473 \cdot 500}{1000} = 736.5 \text{ l/min}$$

becomes

$$P_{1Pu} = \left(54.2 \cdot \frac{500}{1450} + 0.017 \cdot 736.5 \right) \text{ kW}$$

$P_{1Pu} = 31.2 \text{ kW}$

Motorpower output:

$$P_{2Mot} = 1.2 \cdot P_{1Pu} = 37.5 \text{ kW}$$

Select helical

geared motor with

$P = 38 \text{ kW}$

$n = 500 \text{ 1/min}$

$$1 \frac{\text{l}}{\text{min}} \triangleq 0.264 \frac{\text{gal}}{\text{min}} = [\text{US}]$$

Input Power



Diagramm: $n \cdot f_v = f(v)$

Note:

To determine the power consumption always take the max. working viscosity at starting state into consideration. The power of the drive motor should be selected 20% higher than the value determined.

Flange-Mounting Version

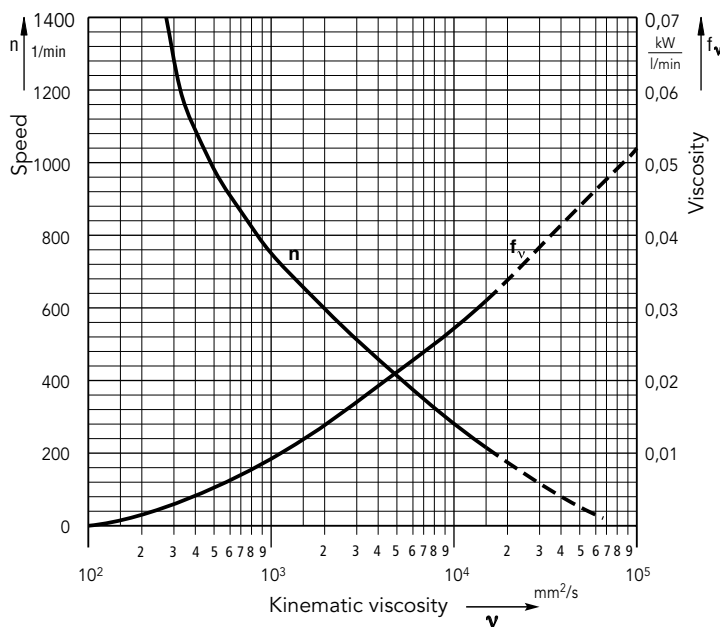
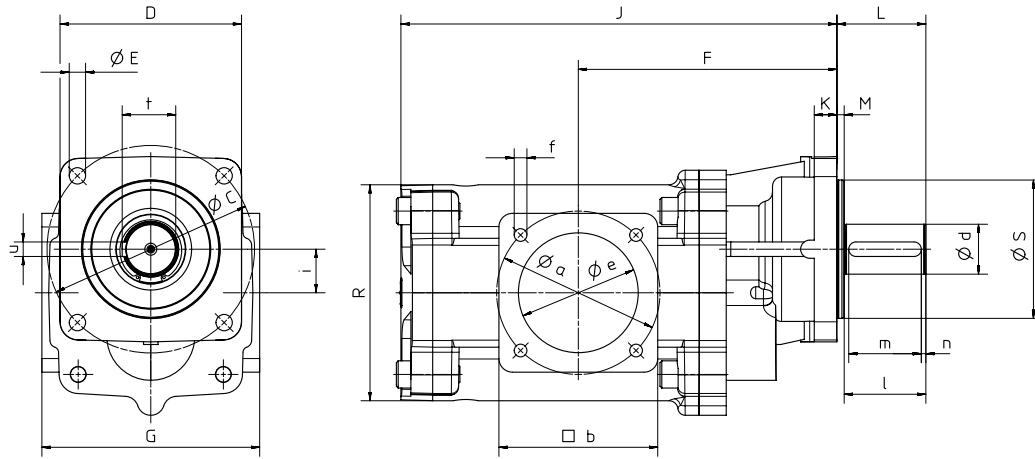

with Pressure valve

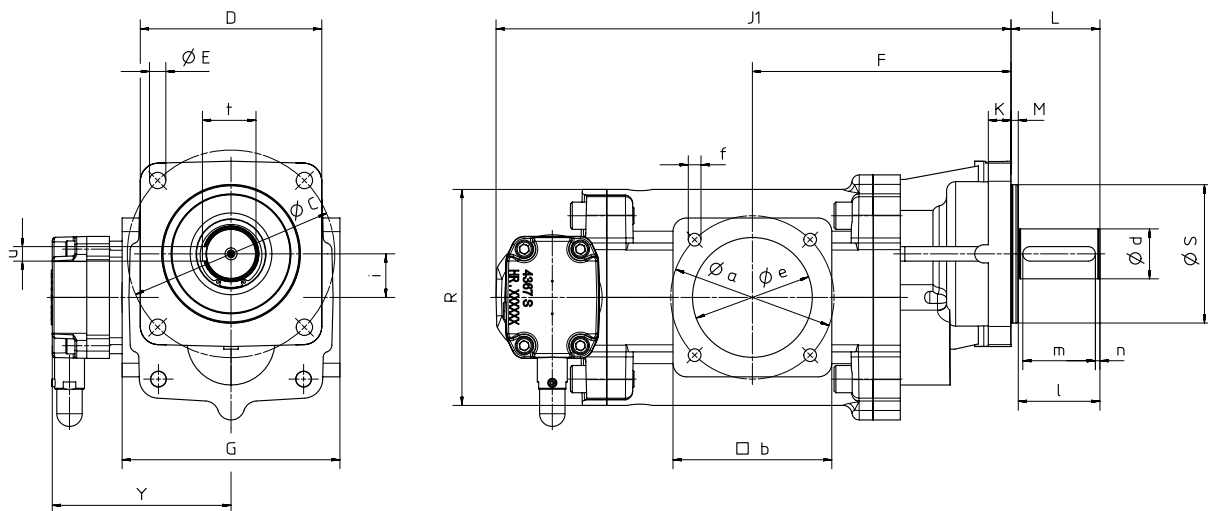

Nominal size	DN	Dimensions																				Weight [kg]						
		Suction and pressure connection				Gear Pump												Shaft end				without	with					
		a	b	e	f	C	D	E	F	G	J	J ₁	K	L	M	R	S _{h8}	i	Y	d _{j6}	l			m	n	t	u	
730	132	180	175	132	M16 30 deep	228.7	200	18	285	240	415	502	25	98	8	238	152.4	48	197	55	90	80	5	59	16	90	99.5	
1000																												
1250	160	210	205	160				330	270	559	646																124	133.5
1500																												125

Accessory Bell Housing and Coupling

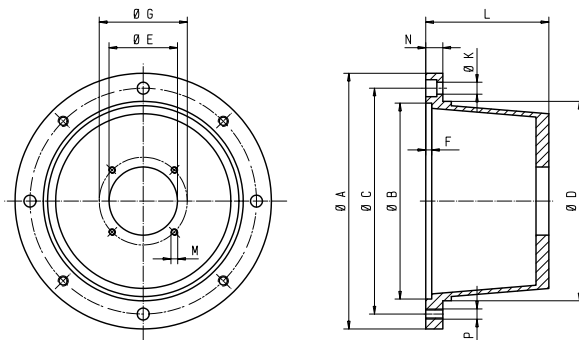

	Motor size	Bell housing	Coupling	Dimensions bell housing											Weight [kg]	
				A	B	C	D	E	F	G	K	L	M	N		P
KF 730...1500	160	PT 350-A-152,4-256	RG 42/55-Z50/55-Z75/42	350	250	300	260	152,4	7	228,6	18	M 16	26	M 16	4,5	
	180	PT 350-A-152,4-256	RG 42/55-Z50/55-Z75/48	350	250	300	260								256	4,5
	200	PT 400-A-152,4-228	RG 42/55-Z50/55-Z50/55	400	300	350	300								228	5
	225	PT 450-A-152,4-262	RG 48/62-Z56/55-Z56/60	450	400	450	350								262	7
	250	PT 550-A-152,4-265	RG 55/74-Z65/55-Z65/65	550	450	500	450								265	11,5
	280	PT 550-A-152,4-275	RG 65-Z75/55-Z75/75	550	450	500	450								275	13
315	PT 660-A-152,4-310	RG 75-Z85/55-Z85/80	660	550	600	550	8	22	310	32	M 20	18,5				

Hub material RG = Grey cast iron

Accessory Connections

KF730... 1000

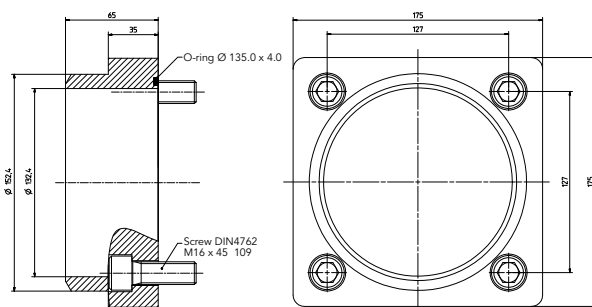

KF1250... 1500

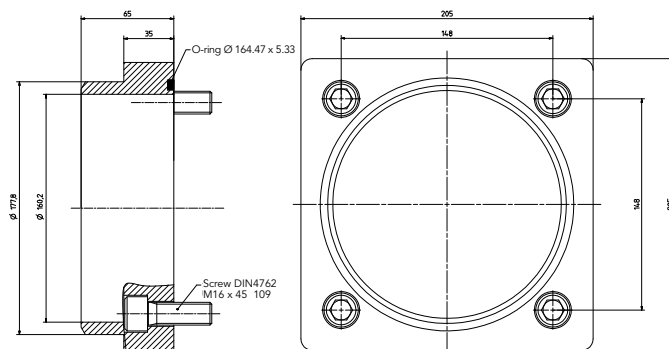

Dimensions in mm

Motor-Pump Assemblies

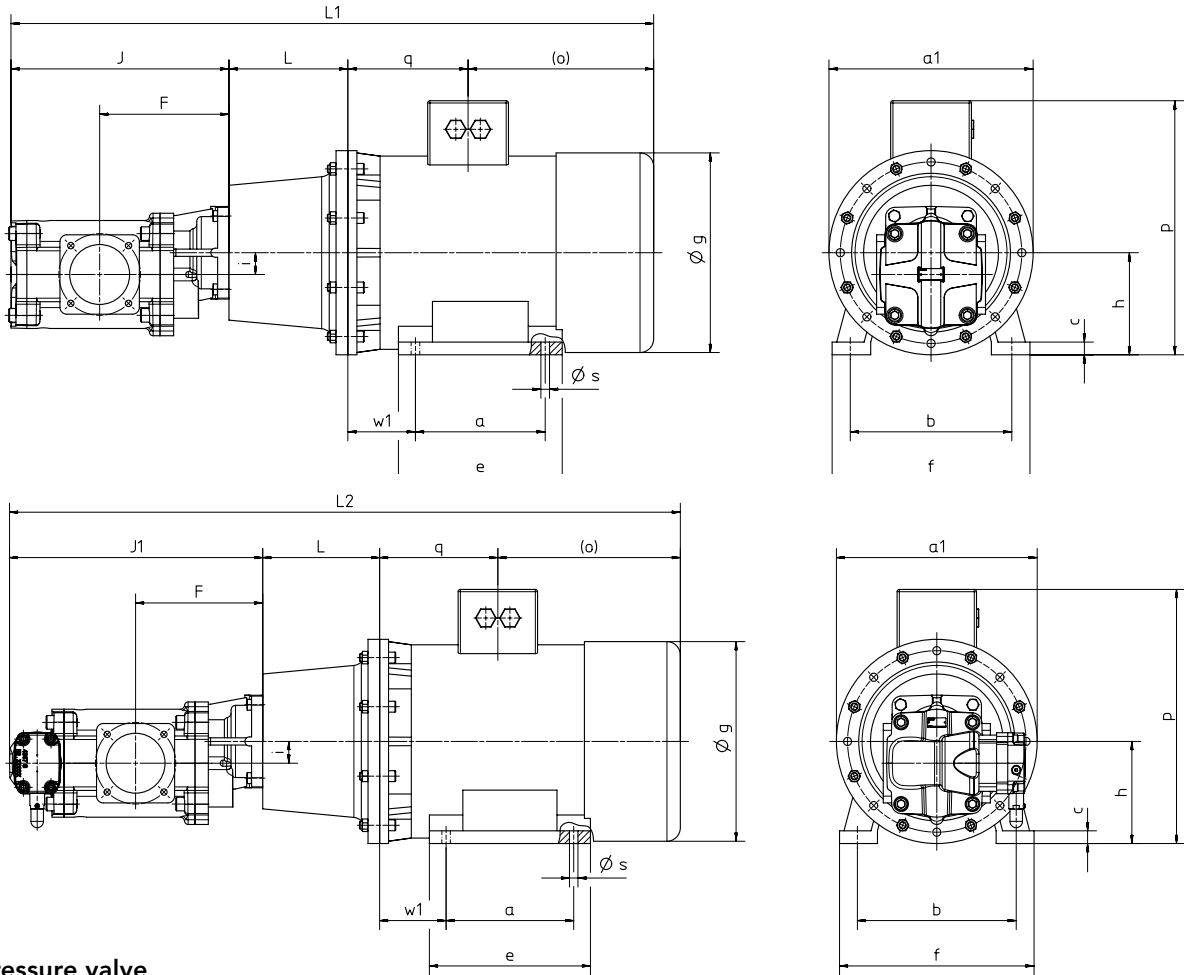

with Pressure valve

Pump sizes

Nominal size	F	J	J ₁	I
730	285	415	502	48
1000		481	568	
1250	330	559	646	
1500				

Motor-Pump Assemblies

Size	Motor				Bell housing	Coupling	Total weight ⁽¹⁾ [kg]			
	6 pole		4 pole				KF 730	KF 1000	KF 1250	KF 1500
	power [kW]	speed [1/min]	power [kW]	speed [1/min]						
160M	7.5	955	11.0	1440	PT 350-A-152.4-256	RG 42/55-Z50/55-Z75/42	260.8	272.8	294.8	295.8
160L	11.0	960	15.0	1440		RG 42/55-Z50/55-Z75/48	266.4	278.4	300.4	301.4
180M	-		18.5	1445		RG 42/55-Z50/55-Z75/48	286.9	298.9	320.9	321.9
180L	15.0	960	22.0	1460		RG 42/55-Z50/55-Z75/48	311.5	323.5	345.5	346.5
200M	18.5	965	30.0	1460	PT 400-A-152.4-228	RG 42/55-Z50/55-Z50/55	385.9	397.9	419.9	420.9
200L	22.0	965	-	-		RG 42/55-Z50/55-Z50/55	415.4	427.4	449.4	450.4
225S	-	-	37.0	1470	PT 450-A-152.4-262	RG 48/62-Z56/55-Z56/60	460.3	472.3	494.3	495.3
225M	30.0	975	45.0	1480		RG 48/62-Z56/55-Z56/60	517.4	529.4	551.4	552.4
250M	37.0	975	55.0	1480	PT 550-A-152.4-265	RG 55/74-Z65/55-Z65/65	613.5	625.5	647.5	648.5
280S	45.0	980	75.0	1480	PT 550-A-152.4-275	RG 65-Z75/55-Z75/75	809.0	821.0	843.0	844.0
280M	55.0	980	90.0	1480		RG 65-Z75/55-Z75/75	865.0	877.0	899.0	900.0
315S	75.0	980	110.0	1480		RG 65-Z75/55-Z75/75	1212.7	1224.7	1246.7	1247.7
315M	90.0	980	132.0	1480	PT 660-A-152.4-310	RG 75-Z85/55-Z85/80	-	1359.1	1381.1	1382.1
315L	110.0	980	160.0	1480		RG 75-Z85/55-Z85/80	-	1448.7	1470.7	1471.7

⁽¹⁾ Pump, motor, bell housing and coupling

Dimensions

Size	Dimensions ⁽¹⁾																	
	730	1000	1250	1500	L	a ₁	a	b	c	e	f	g	h	o	p	q	s	w ₁
	L ₁	L ₁	L ₁	L ₁														
160M	1166	1232	1310	1310	256	350	210	254	17	332	315	325	160	323	410	172	15	108
160L	1211	1277	1355	1355	256	350	254	254	17	332	315	325	160	368	410	172	15	108
180M	1248	1314	1392	1392	256	350	241	279	27	320	350	360	180	336	450	241	15	121
180L	1286	1352	1430	1430	256	350	279	279	27	320	350	360	180	354	450	261	15	121
200M/L	1301	1367	1445	1445	228	400	305	318	25	358	388	399	200	373	500	285	19	133
225S	1351	1417	1495	1495	262	450	286	356	28	341	436	465	225	391	560	283	19	149
225M	1376	1442	1520	1520	262	450	311	356	28	386	436	465	225	404	560	295	19	149
250M	1458	1524	1602	1602	265	550	349	406	30	443	484	506	250	436	616	342	24	168
280S	1534	1600	1678	1678	275	550	368	457	34	459	557	559	280	470	673	374	24	190
280M	1585	1651	1729	1729	275	550	419	457	34	510	557	559	280	495,5	690	399,5	24	190
315S	1940	2006	2084	2084	310	660	508	508	45	672	628	682	315	870	825	345	28	216
315M/L	1790	1856	1934	1934	310	660	406	508	45	590	628	682	315	720	825	345	28	216

Note

⁽¹⁾ Dimensions dependent on motor typ

(drawing: manufacture ADDA).

Other manufactures motors can be supplied on request.

Motor frame sizes are based on DIN 42673/677.

All pump and motor sizes can be combined.

I Gear Pumps

Low and high-pressure gear pumps for lubricating oil, hydraulic, process and test bench applications, fuel and metering systems.



I Flow Measurement

Gear, turbine and screw type flow meters and electronics for volume and flow, metering and consumption in the chemical industry, hydraulic, process and test bench technology.



I Hydraulics

Single and multistage high-pressure gear pumps, gear motors and valves for construction machinery, municipal vehicles, agricultural vehicles, special vehicles and truck bodies.



I Valves

Cetop valves for all requirements stationary and mobile applications. Pressure, switching and stop valves with pipe connection for high flow rates. Special valves.



KRACHT®

KRACHT GmbH · Gewerbestraße 20 · 58791 Werdohl, Germany
 Phone +49 2392.935 0 · Fax +49 2392.935 209
 E-Mail info@kracht.eu · Web www.kracht.eu