

KRACHT®

- | Gear Pumps
- | Flow Measurement
- | Hydraulics
- | Valves

Gear Pumps

DT
DuroTec®

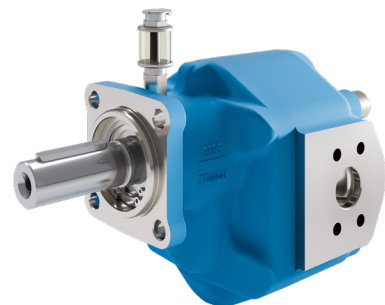

Description

DuroTec® Gear Pumps DT for abrasive and poor lubricating fluids.

In the year 1990, KRACHT initiated the development of Gear Pumps for abrasive and poor lubricating fluids. Since then, this development has been subsequently improved.

The limit of applications of Gear Pumps has been reached when the transfer medium does not have the required lubricity for a proper function of the pump and a high working pressure is needed at the same time. Such problematic fluids are for example silicates (sodium silicate), isocyanates and

polyols with hard fillers as can be found in the PUR-technology. Under air or humidity influence, crystallisation of these fluids occurs and aggravates the lack of lubricity.

The gear (gear wheel and shafts) is surrounded by SIC bearing bush. The gear is high-rigid protected against wear, taken the requirements regarding material, heat treatment, surface geometry into consideration when using this coating technology.

Highest demands have been fulfilled by our own manufacturing quality and the involved coating specialists.

Construction DT 3

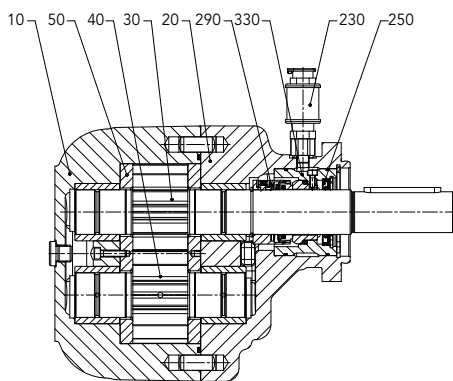

- 10 Housing
- 20 Flange cover
- 30 Shaft
- 40 Bolt
- 50 Sliding plate
- 230 Quench tank
- 250 Shaft seal
- 290 Mechanical seal
- 330 Seal holder

Construction DT 5

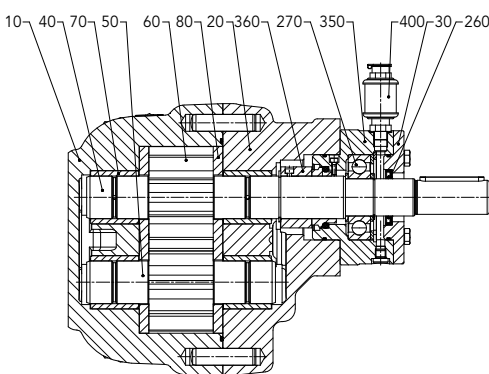

- 10 Housing
- 20 Flange cover
- 30 Centering disc
- 40 Shaft
- 50 Bolt
- 60 Gearing
- 70 Bearing bush
- 80 Sliding plate
- 260 Shaft seal
- 270 Roller bearing
- 350 Mounting mechanical seal
- 360 Mechanical seal
- 400 Quench tank

Depending on the medium to be transferred, working pressures up to 100 bar are possible with driving speeds of about 1000 rpm. Solid body parts with a size <math>< 50 \mu\text{m}</math> and a hardness acc. to Vickers <math>< 2500</math> will be accepted in the transfer medium.

The main field of application for the new DuroTec® Gear Pumps DT are mainly multi-component-systems in the PUR-technology. Everywhere where standards Gear Pumps do not reach a satisfying lifetime, e.g. where polyols with hard fillers have to be handled, this Gear Pump offers a reliable alternative.

Materials

Housing	EN-GJL-300 (GG 30)
Flange cover	EN-GJL-300 (GG 30)
Gearing	Steel, hard material coated
Sliding plates	Steel, hardened and nitrated
Bearing	SIC bearing bush
Shaft sealing	Mechanical seal with Quench chamber incl. Quench tank

Characteristics

Geometrical displacement	V_g	DT 3 = 63, 100, 125 cm ³ /rev DT 5 = 150, 200, 250 cm ³ /rev
Mounting position		horizontal
Fixing type		DT 3 = flange (4-hole flange DIN ISO 7653) DT 5 = flange (SAE-C 2-hole-flange)
Inlet port		SAE 1½" – 2" – 2½" flange
Outlet port		SAE 1¼" – 2" flange
Max. working pressure		100 bar
Max. inlet pressure		20 bar
Speed	n_{max}	= 1000 1/min
Viscosity	mm ² /s	500 up to 50 000 (higher viscosities on request)
Fluid temperature		max. 150 °C
Ambient temperature	$\vartheta_{u \min}$ $\vartheta_{u \max}$	= - 20 °C = 60 °C
Shaft end		Cylindrical shaft

Input Power



Diagramm: $n, f_v = f(v)$

Note:

To determine the power consumption, always take the max. working viscosity at starting state into consideration.

The power of the drive motor should be selected 20% higher than the value determined.

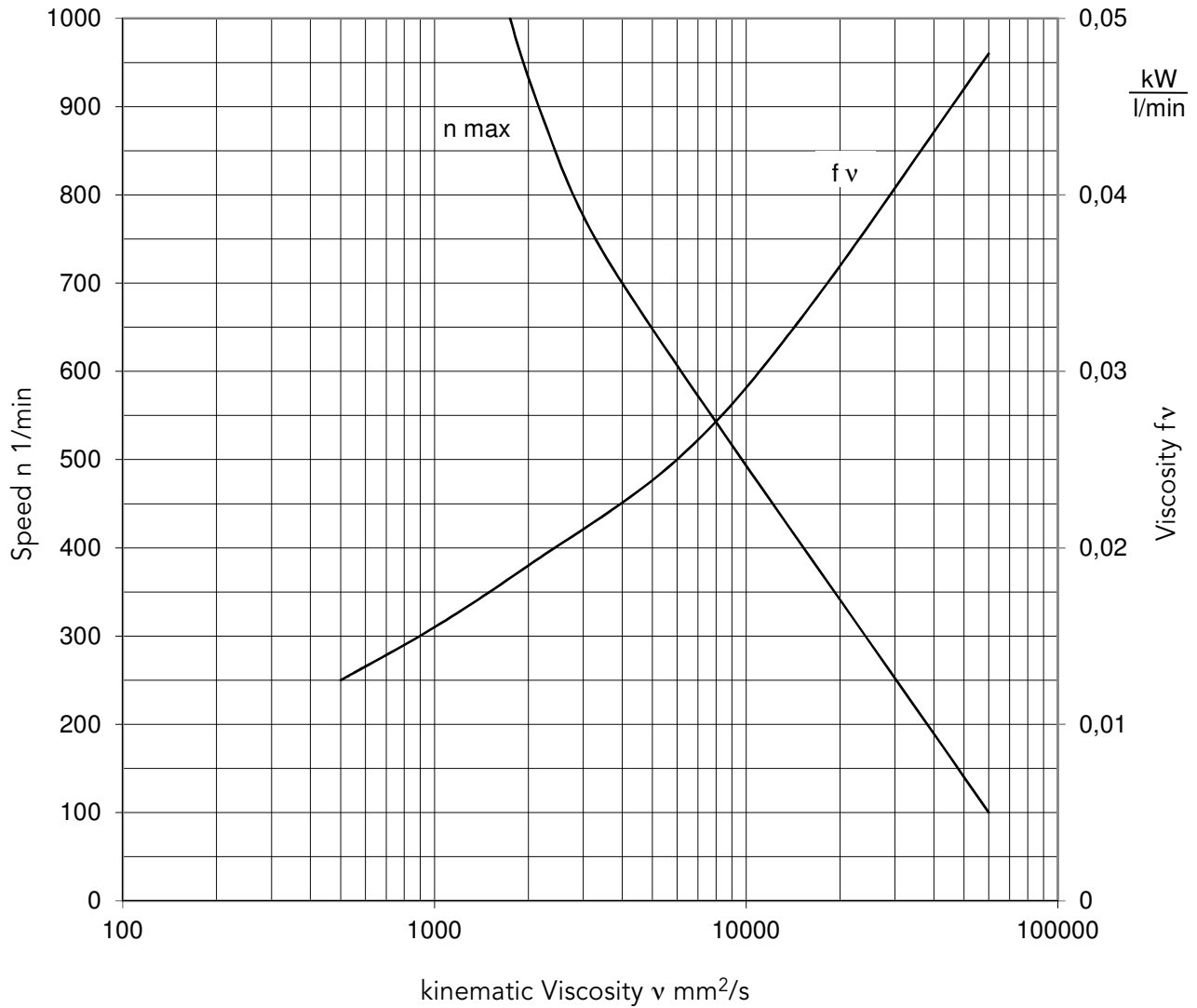
Discharge Flow / Input Power

Calculation

- P_{Pu} = Pump power consumption (kW)
- P = Power consumption
- n = Speed (1/min)
Dependent on viscosity!
(see chart)
- f_v = Viscosity factor $\left[\frac{\text{kW}}{\text{l/min}} \right]$
(see chart)
- Q = Discharge flow (l/min) with $Q = \frac{V_g \cdot n}{1000}$
- V_g = Geometrical displacement (cm³/rev)

Conversion factors

- 1 bar \triangleq 14.5 $\frac{\text{lb}}{\text{in}^2}$ = 14.5 psi
- 1 $\frac{\text{l}}{\text{min}}$ \triangleq 0.220 $\frac{\text{gal}}{\text{min}}$ = [U.K.]
- 1 $\frac{\text{l}}{\text{min}}$ \triangleq 0.264 $\frac{\text{gal}}{\text{min}}$ = [US]

Example: Pump type DT 3/63

- Viscosity $v = 3000 \text{ mm}^2/\text{s}$
- Working pressure $p = 50 \text{ bar}$
- at $P = 2.89 \text{ kW}$
- $n = 500 \text{ 1/min}$
- $f_v = 0.017 \frac{\text{kW}}{\text{l/min}}$
- $Q = 28 \text{ l/min}$

becomes

$$P_{Pu} = (2.89 + 0.017 \cdot 28) \text{ kW}$$

$$P_{Pu} = 3.37 \text{ kW}$$

Motorpower output:

$$P_{Mot} = 1.2 \cdot P_{Pu} = 4 \text{ kW}$$

Select helical

geared motor with

$$P = 4.0 \text{ kW}$$

$$n = 500 \text{ 1/min}$$

Calculation Formulas for Hydraulic Pumps

Characteristic data, formula signs, units

Discharge flow / input flow	Q	l/min
Pump / motor displacement	V_g	cm ³ /rev
Pressure	p	bar
Speed of rotation	n	1/min
Torque	M	Nm
Power	P	kW
Total efficiency	η_{tot}	-
Volumetric efficiency	η_{vol}	-
Hydr./mech. efficiency	η_{hm}	-
Flow velocity	v	m/s
Pipe diameter	d	mm

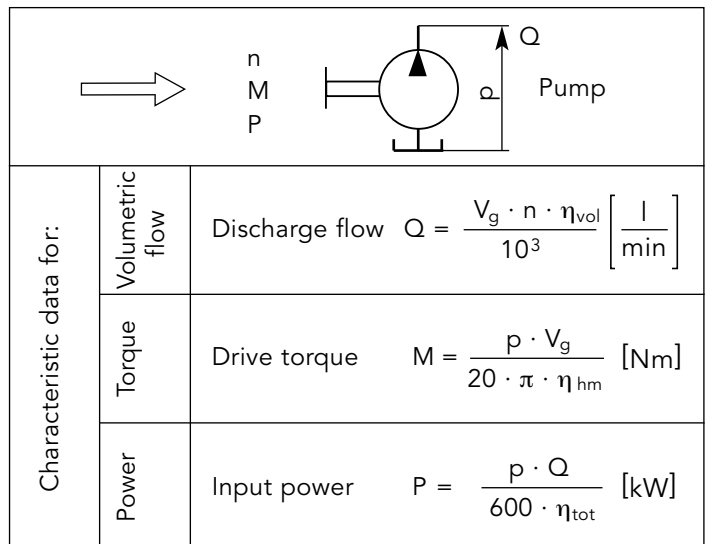

General

$$Q_{th} = V_g \cdot n, \quad \eta_{tot} = \eta_{vol} \cdot \eta_{hm},$$

$$M = 9549 \cdot \frac{P}{n} \quad v = 21.22 \cdot \frac{Q}{d_2} \quad P = \frac{M \cdot n}{9549}$$

Type Key

Ordering example

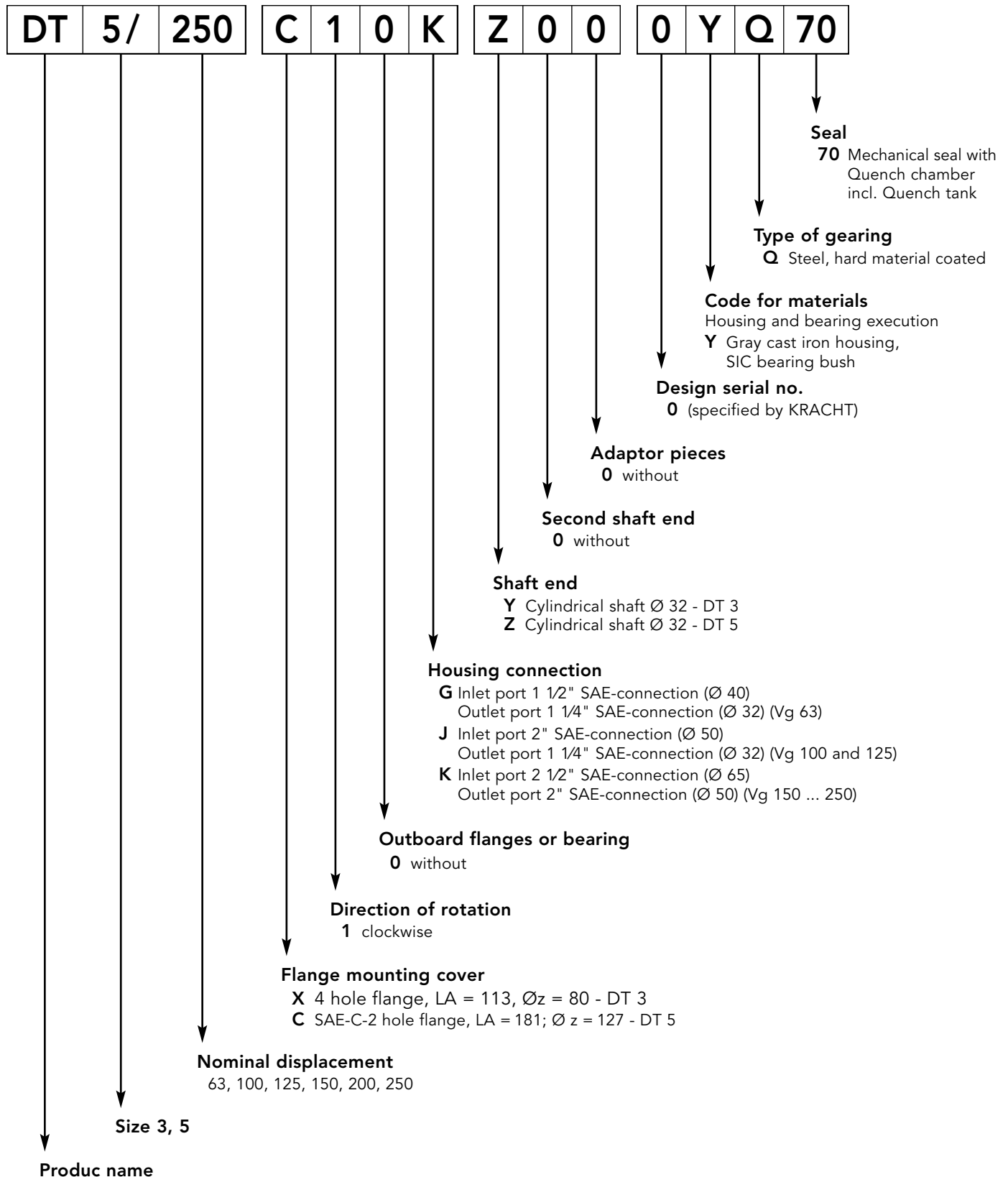

Dimensions DT 3/63

Weight 25 kg

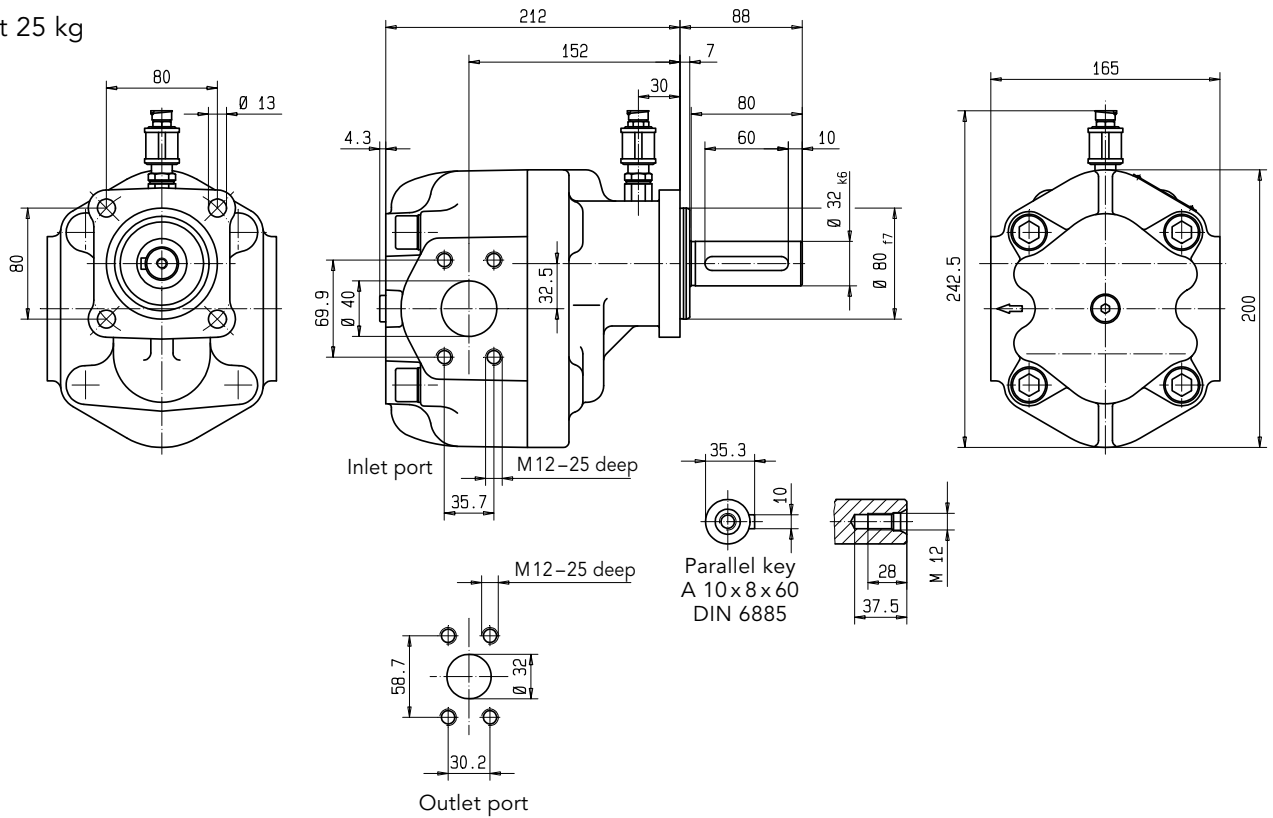

Dimensions DT 3/100

Weight 29 kg

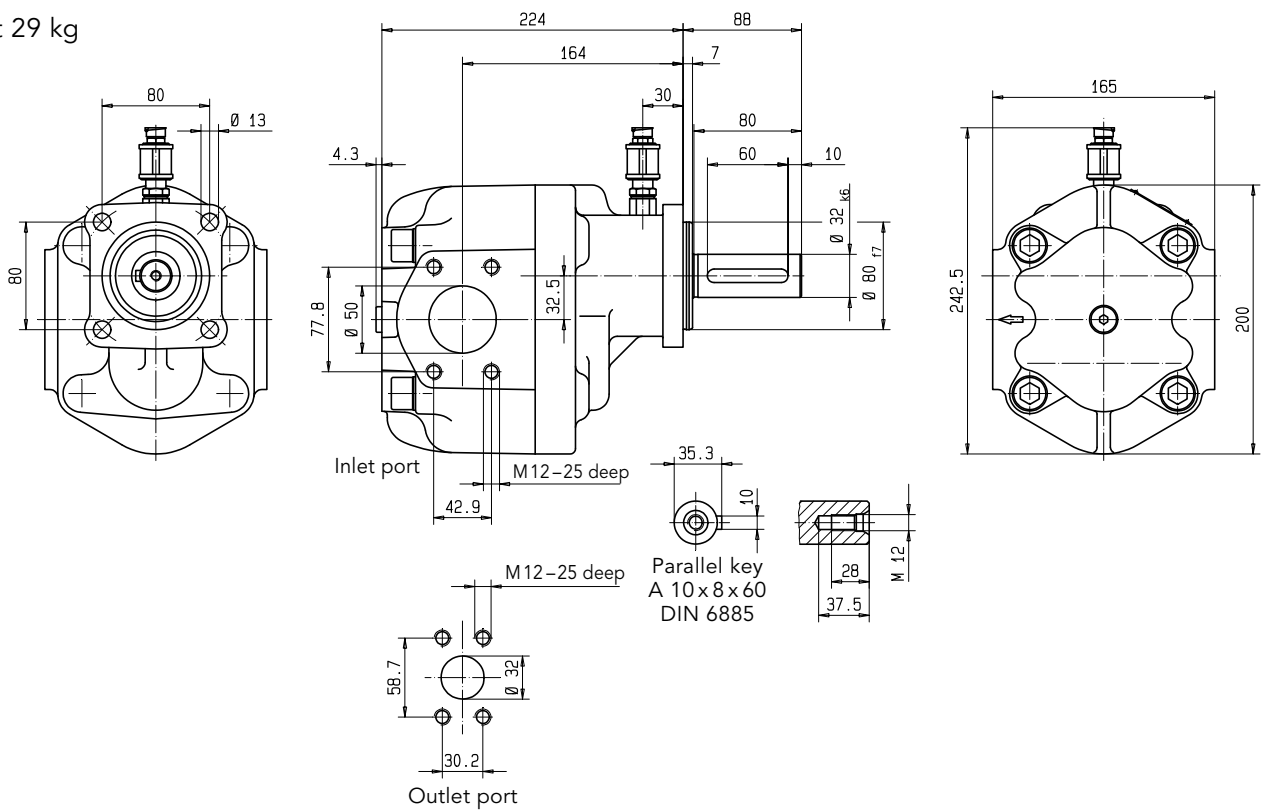

Dimensions DT 3/125

Weight 32 kg

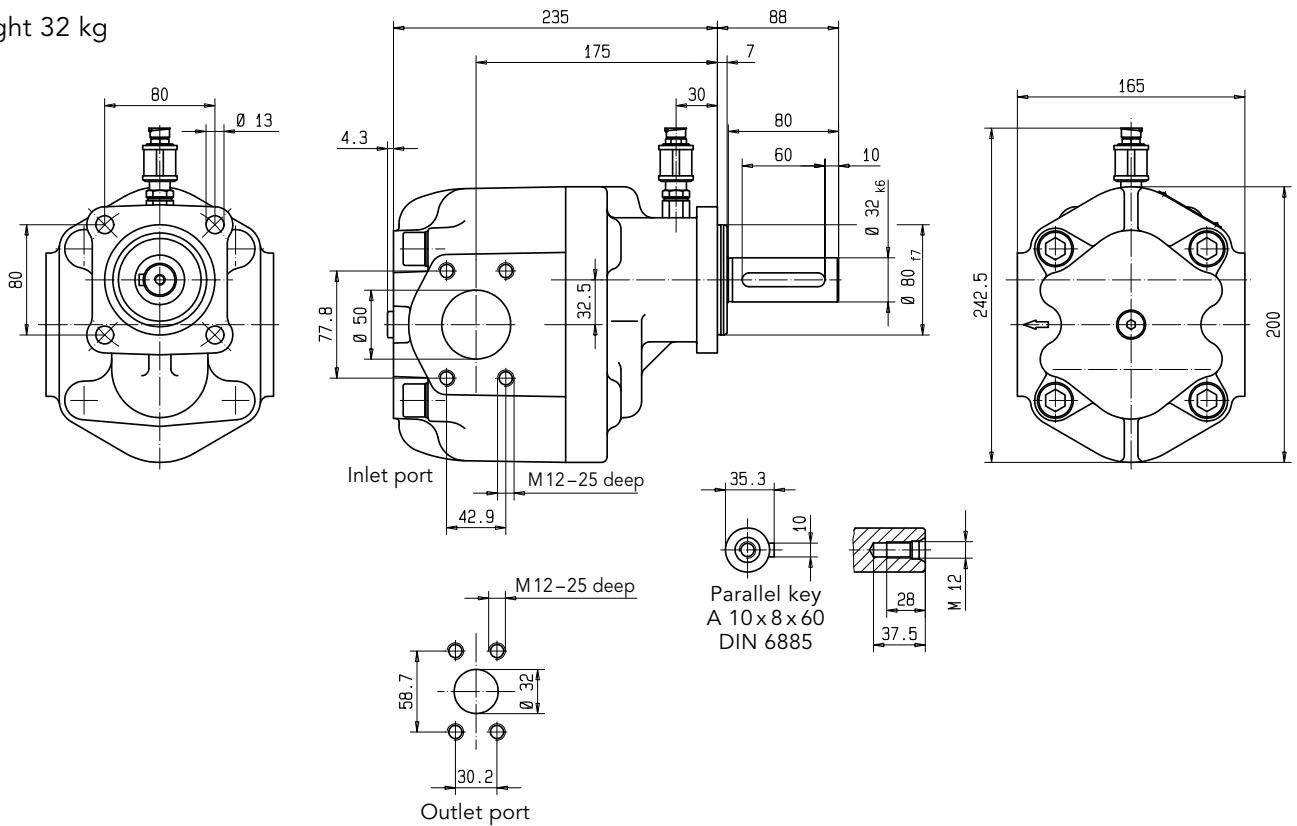

Dimensions DT 5/150

Weight 49 kg

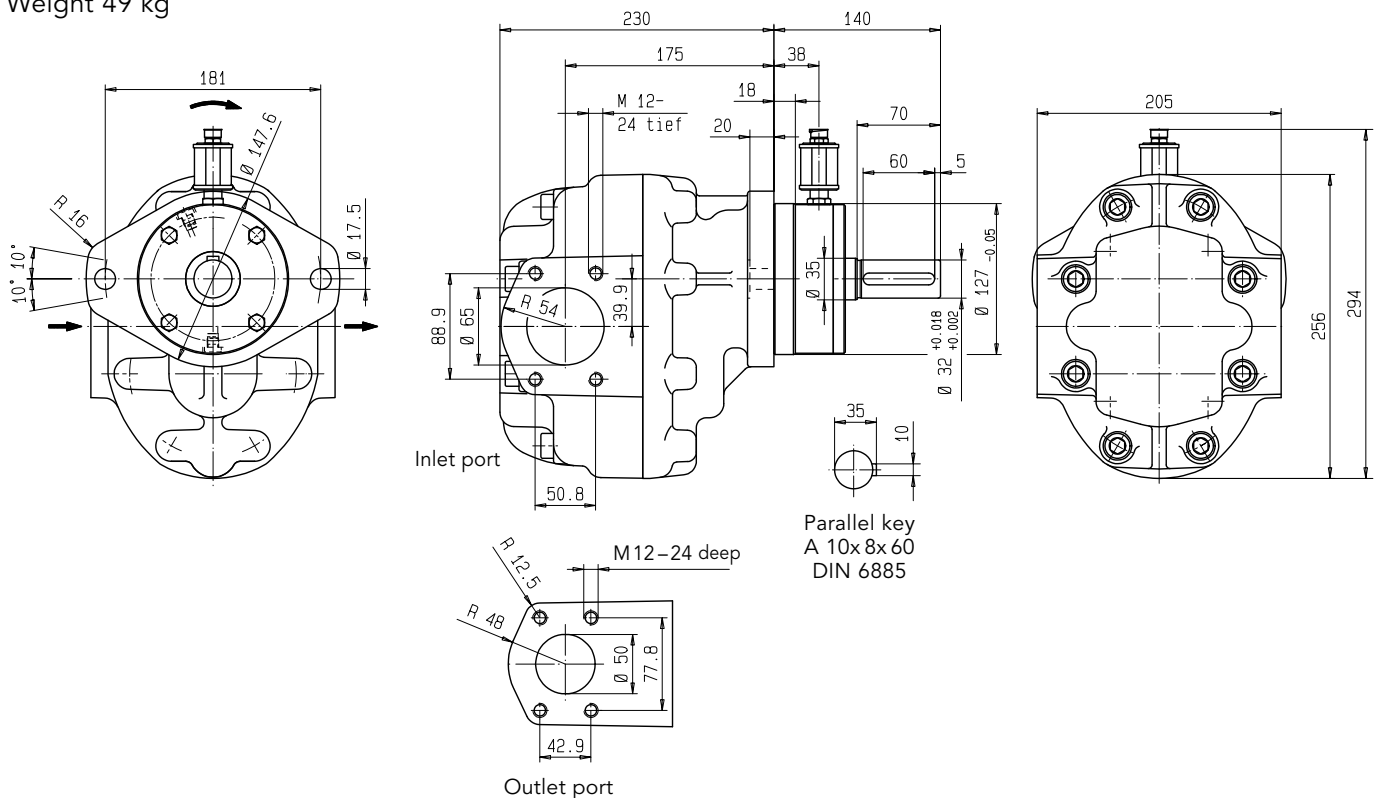

Dimensions in mm

Dimensions DT 5/200

Weight 53 kg

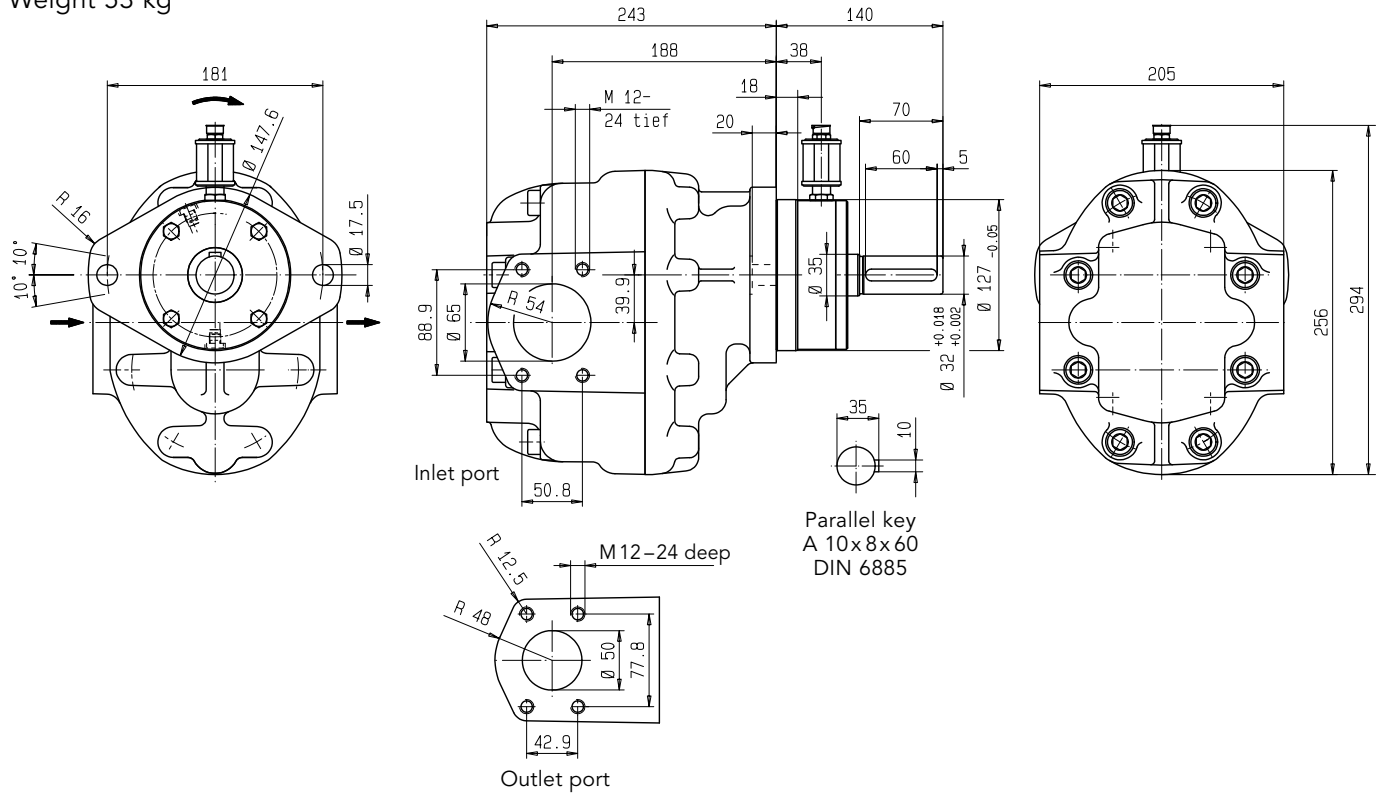

Dimensions DT 5/250

Weight 57 kg

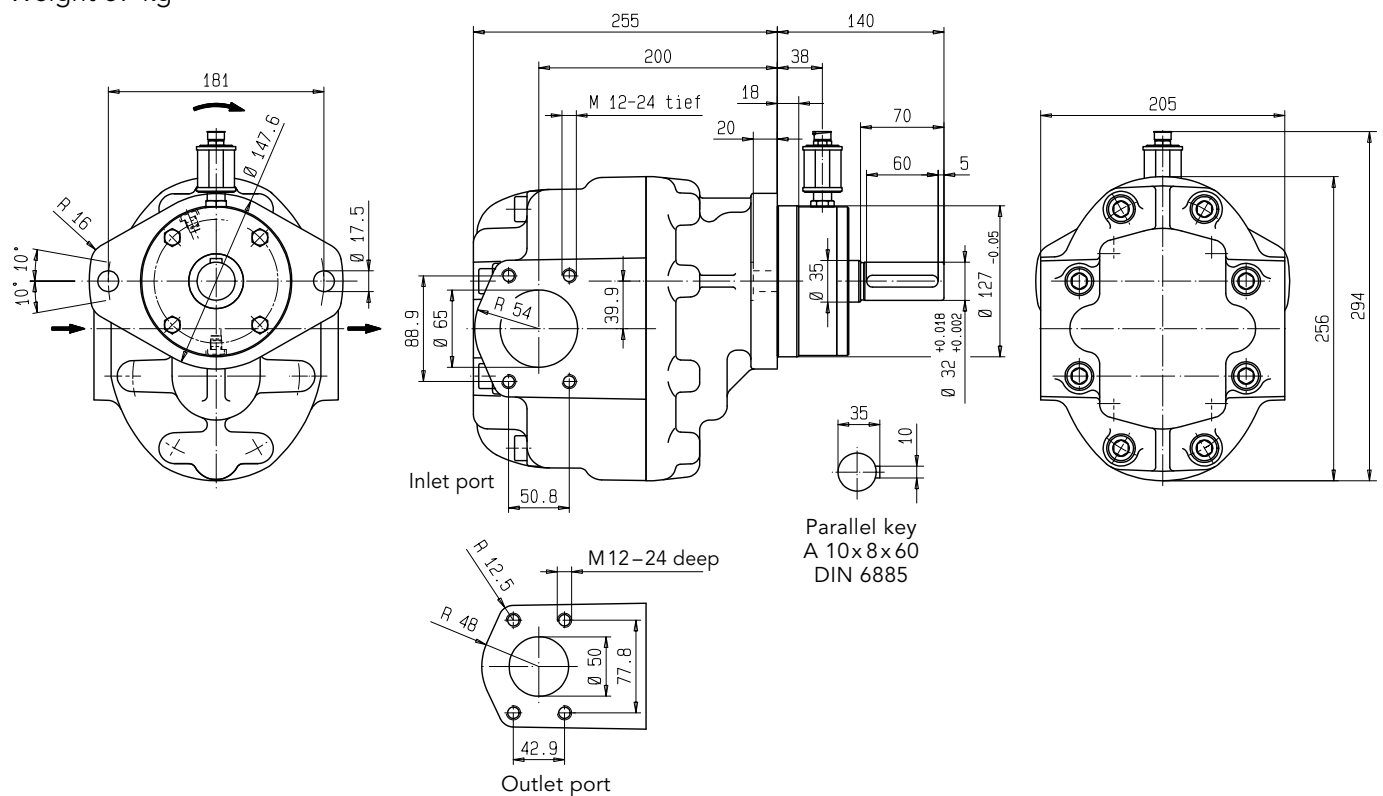

Motor-Pump Assemblies DT 3

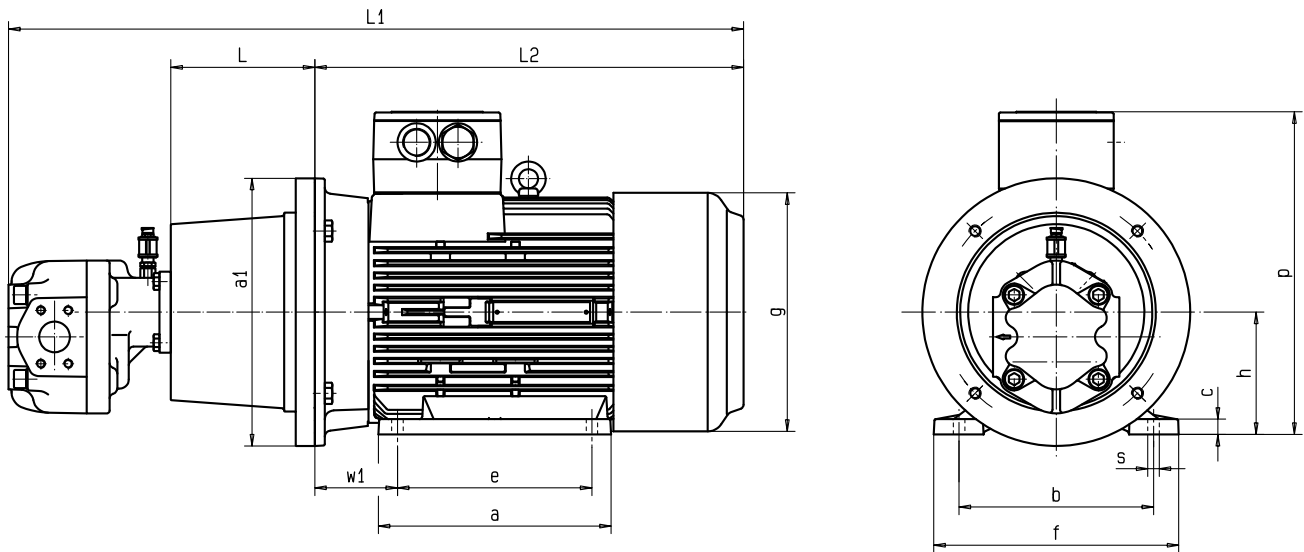

DT 3

Size	Motor 8-pole		Motor 6-pole		Motor 4-pole		Bell housing	Coupling
	Power kW	Speed 1/min	Power kW	Speed 1/min	Power kW	Speed 1/min		
132 S	2.2	710	3.0	960	5.5	1440	PL300/07/67-00	RS28/38-Z60/32-Z60/38
132 M	3.0	710	5.5	970	7.5	1440		
160 M	4.0	720	7.5	970	11.0	1460	PK350/06/58-00	RG42/55-Z50/32-Z75/42
160 L	5.5	720	11.0	970	15.0	1470		
180 M	–	–	–	–	18.5	1470	PK350/06/58-00	RG42/55-Z50/32-Z75/48
180 L	11.0	730	15.0	970	22.0	1480		
200 L	15.0	730	22.0	970	30.0	1480	PK400/04/34-00	RG42/55-Z50/32-Z75/55
225 S	18.5	730	–	–	37.0	1480	PK450/02/55-00	BOWEX M65. 60-32
225 M	22.0	730	30.0	980	45.0	1480		

All motor dimensions and date refer to AC motors; other motor makes on enquiry. Motor type IMB35.

DT 3

Size	DT3/63	DT3/100	DT3/125													
	L1	L1	L1	L	a ₁	a	b	c	e	f	g	h	L ₂	p	s	w ₁
132 S	808	820	831	196	300	186	216	15	140	262	258	132	395	320	12	89
132 M	846	858	869	196	300	224	216	15	178	262	258	132	433	320	12	89
160 M	914	926	937	204	350	260	254	20	210	314	314	160	498	411	15	108
160 L	958	970	981	204	350	304	254	20	254	314	314	160	542	411	15	108
180 M	999	1011	1022	204	350	311	279	22	241	349	355	180	578	447	15	121
180 L	1037	1049	1060	204	350	349	279	22	279	349	355	180	616	447	15	121
200 L	1090	1102	1113	204	400	369	318	25	305	388	397	200	669	525	19	133
225 S	1135	1147	1158	234	450	368	356	28	286	431	446	225	684	547	19	149
225 M	1160	1172	1183	234	450	393	356	28	311	431	446	225	709	547	19	149

All pump nominal sizes and motor sizes can be combined with each other.

Motor-Pump Assemblies DT 5

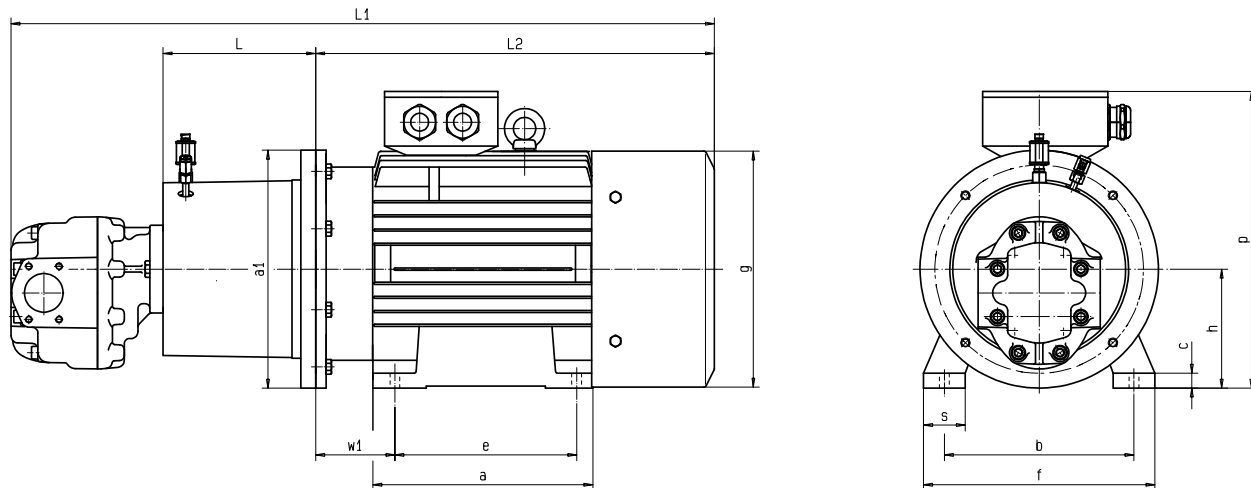

DT 5

Size	Motor 8-pole		Motor 6-pole		Motor 4-pole		Bell housing	Coupling
	Power kW	Speed 1/min	Power kW	Speed 1/min	Power kW	Speed 1/min		
160 M	4.0	720	7.5	970	11.0	1460	PL 350/07/64-special	Bowex M42.42-32
160 L	5.5	720	11.0	970	15.0	1470		
180 M	–	–	–	–	18.5	1470	PL 350/07/64-special	Bowex M48.48-32
180 L	11.0	730	15.0	970	22.0	1480		
200 L	15.0	730	22.0	970	30.0	1480	PL 400/05/18-special	Bowex M65.55-32
225 S	18.5	–	–	–	37.0	1480	PL 450/03/15-special	Bowex M65.60-32
225 M	22.0	730	30.0	980	45.0	1480		
250 M	30.0	730	37.0	980	55.0	1480	PL 550/03/21-special	Bowex M65.65-32

All motor dimensions and data refer to AC motors; other motor makes on enquiry. Motor type IMB35.

DT 5

Size	DT 5/150	DT 5/200	DT 5/250													
	L1	L1	L1	L	a ₁	a	b	c	e	f	g	h	L ₂	p	s	w ₁
160 M	984	997	1016	256	350	260	254	20	210	314	314	160	498	411	15	108
160 L	1028	1041	1016	256	350	304	254	20	254	314	314	160	542	411	15	108
180 M	1064	1077	1052	256	350	311	279	22	241	349	355	180	578	447	15	121
180 L	1102	1115	1052	256	350	349	279	22	279	349	355	180	616	447	15	121
200 L	1155	1168	1180	256	400	369	318	25	305	388	397	200	669	525	19	133
225 S	1199	1212	1252	285	450	368	356	28	286	431	446	225	684	547	19	149
225 M	1224	1237	1252	285	450	393	356	28	311	431	446	225	709	547	19	149
250 M	1295	1308	1413	295	550	445	406	30	349	484	485	250	770	608	24	168

All pump nominal sizes and motor sizes can be combined with each other.

I Gear Pumps

Low and high-pressure gear pumps for lubricating oil, hydraulic, process and test bench applications, fuel and metering systems.



I Flow Measurement

Gear, turbine and screw type flow meters and electronics for volume and flow, metering and consumption in the chemical industry, hydraulic, process and test bench technology.



I Hydraulics

Single and multistage high-pressure gear pumps, gear motors and valves for construction machinery, municipal vehicles, agricultural vehicles, special vehicles and truck bodies.



I Valves

Cetop valves for all requirements stationary and mobile applications. Pressure, switching and stop valves with pipe connection for high flow rates. Special valves.



KRACHT®

KRACHT GmbH · Gewerbestraße 20 · 58791 Werdohl, Germany
 Phone +49 2392.935 0 · Fax +49 2392.935 209
 E-Mail info@kracht.eu · Web www.kracht.eu