

## General description

Fixed displacement vane pump, hydraulically balanced, with capacity determined by the type of ring used and the speed of rotation. The pump is available in eight different displacements, from 3.29 cc to 22.8 cc.

## Technical characteristics

oil viscosity: 25 c.St. (10W), temperature: 45°C, inlet pressure: 0 BAR

Pump type	Geometric displacement		Rated capacity at 7 bar						Max pressure with mineral oil		Speed range with min. oil (rpm)	
			1000 rpm		1200 rpm		1500 rpm					
	cm <sup>3</sup> /g	(in <sup>3</sup> /r)	l/min	(gpm)	l/min	(gpm)	l/min	(gpm)	bar	(psi)	min	max
<b>B1G10</b>	3,29	(0.20)	3,21	(0.85)	3,78	(1)	4,70	(1.25)	175	(2500)	650	4800
<b>B1G15</b>	5,50	(0.33)	5,42	(1.43)	6,32	(1.70)	7,86	(2.10)	175	(2500)	650	4800
<b>B1G20</b>	6,53	(0.40)	6,45	(1.70)	7,57	(2)	9,40	(2.50)	175	(2500)	650	4500
<b>B1G30</b>	9,82	(0.60)	9,72	(2.57)	11,35	(3)	14,20	(3.75)	175	(2500)	650	4000
<b>B1G40</b>	13,10	(0.80)	12,91	(3.41)	15,14	(4)	18,90	(5.00)	175	(2500)	650	3400
<b>B1G50</b>	16,39	(1.00)	16,25	(4.29)	18,92	(5)	23,60	(6.25)	175	(2500)	650	3200
<b>B1G60</b>	19,50	(1.19)	19,44	(5.14)	22,71	(6)	28,40	(7.50)	150	(2200)	650	3000
<b>B1G70</b>	22,80	(1.39)	22,36	(5.91)	26,49	(7)	33,10	(8.75)	140	(2000)	650	2800

**Hydraulic fluids:** mineral oils, phosphate ester based fluids, water emulsions in oil, water-glycol fluids.

**Viscosity range (with mineral oil):** from 13 to 860 cSt. (13 to 54 cSt. recommended).

**Filtration:** for the inlet - 149 micron abs., for the return line - 25 micron abs. or better (with synthetic fluids: for the return line - 10 micron abs. or better).

**Inlet pressure (with mineral oil):** from -0,17 to +0,35 bar (-2.5 + 5 psi),  
(with synthetic fluids and water-in-oil emulsion): from -0,10 to +0,35 bar (-1.5 + 5 psi)

**Operating temperature:** with mineral oil -10°C to +70°C (+30°C to +60°C recommended), with water based fluids +15°C to +50°C.

**Drive:** direct and coaxial by means of a flexible coupling.

## Use limits with special fluids

Pump type	Maximum pressure						Speed range (rpm)	
	syntetic fluid		water-glycol		water-in-oil emulsion		syntetic fluid, water-glycol water-in-oil emulsion	
	bar	(psi)	bar	(psi)	bar	(psi)	min	max
<b>All</b>	140	(2000)	126	(1800)	105	(1500)	650	1800

## Installation dimensions mm

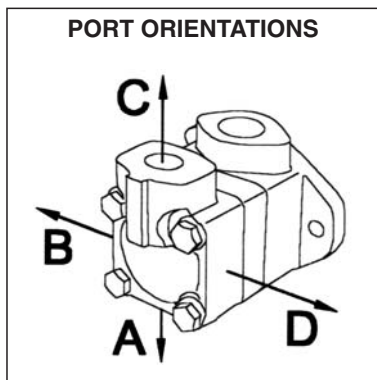
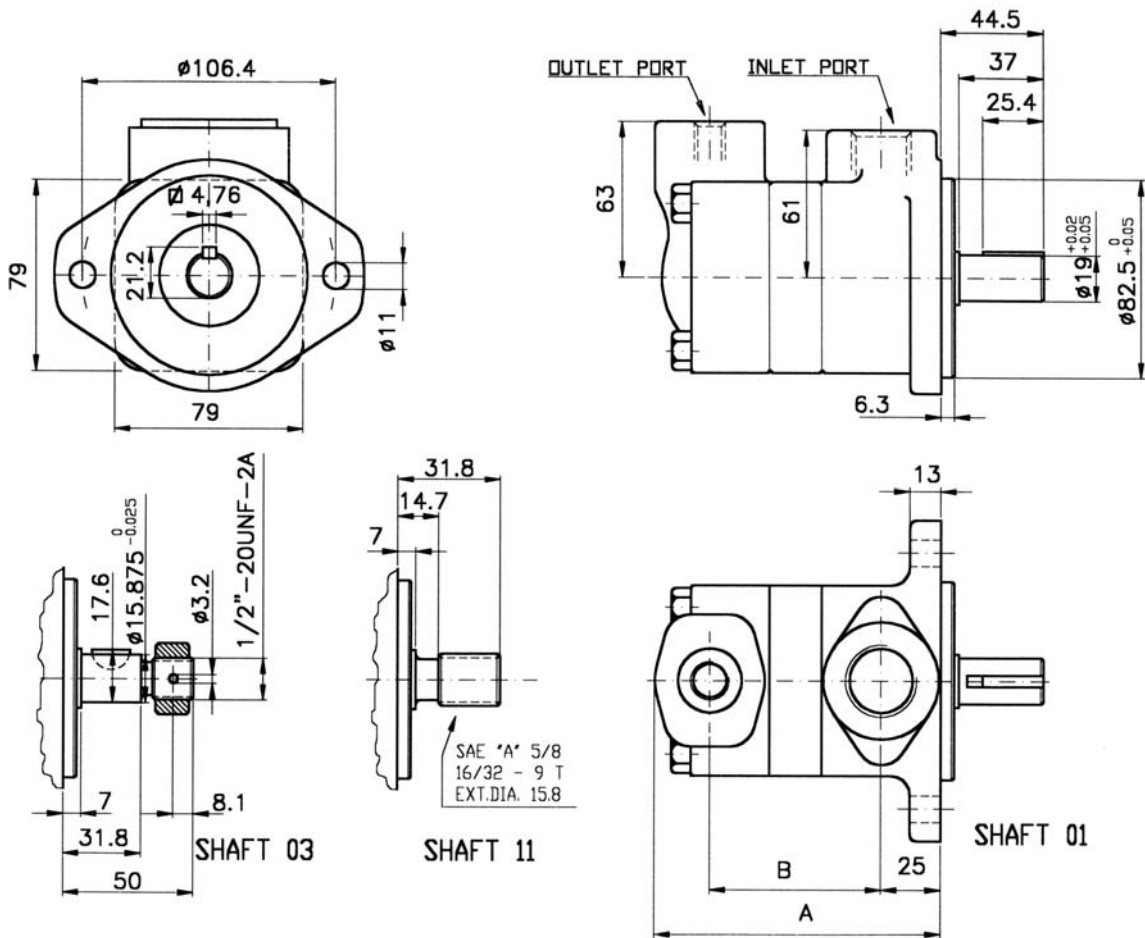

### Pump length

Pump type	A	B
B1G10	116	67.4
B1G15	116	67.4
B1G20	116	67.4
B1G30	116	67.4
B1G40	120	73.7
B1G50	120	73.7
B1G60	127	78.8
B1G70	127	78.8

Approx. weight: 4,5-6,8 kg. (10-15 lbs.)

### Model code breakdown

Nominal size (see table)  
10 15 20 30 40 50 60 70

**B1 G \*\* \* \* \* \* (L)**

Inlet port connection  
**B**= 1" GAS threaded  
**P**= 1" NPT threaded  
**S**= SAE 1-5/16" 12 UNF-2B threaded

Outlet port connection  
**B**= 1/2" GAS threaded  
**P**= 1/2" NPT threaded  
**S**= SAE 3/4" 16 UNF-2B threaded

Rotation (viewed from shaft end)  
**L** = left hand rotation (omit if right hand rot.)

Shaft end options  
**01** = Straight with square key (standard)  
**03** = Threaded with woodruff key  
**11** = Splined "SAE A" 9 teeth 16/32

Outlet port positions (Outlet viewed from cover end)  
**A** = Outlet opposite inlet, **B** = Outlet 90° CCW from inlet,  
**C** = Outlet in line with inlet, **D** = 90° Outlet CW from inlet

## Operating instructions

**Maximum speed:** the maximum speeds given in this catalogue are valid for an atmospheric pressure of 1 bar (14.7 psi) and with ambient temperature in the range of +30°C to +50°C. Higher speeds than those given cause a reduction in the volumetric efficiency, due to cavitation phenomena in the inlet area inside the pump. Sustained excess speed causes a rapid deterioration of the internal components reducing the lifetime of the pump.

**Minimum speed:** Refer to the technical characteristics table of the pump. However, it is possible to operate at lower speeds with certain pump configurations and with appropriate operating temperatures.

**Inlet pressure:** the inlet pressure, measured at the inlet port, should remain within the prescribed limits. Note that pressures lower than minimum limit cause cavitation and pressures above the maximum limit cause abnormal loads on the shaft and the bearings. In both cases this causes a significant reduction in the lifetime of the cartridge.

**Maximum outlet pressure:** the maximum outlet pressure is different for each type of fluid used as can be seen from the corresponding table. With optimal temperature and filtration conditions a pressure peak of +10% is permissible for a maximum time of 0.5 sec.

**Mounting and drive connections:** consider the following indications when preparing the installation drawings for the system:

- the pump is designed to operate with keyed shaft coupled axially and by means of a flexible coupling to the drive;
- the clearance between the keyed shaft and the corresponding sleeve coupling has to be between 0.004 and 0.030 mm;
- avoid axial and radial loads on the shaft;
- the mounting flange has to be perpendicular to the drive shaft, with a maximum error of 0.18 mm every 100 mm;
- when mounting onto a gearbox, or other component without a flexible coupling, it is advisable to order pumps with splined shaft. In this case the clearance between splines has to be between 0.013 and 0.051 mm on the pitch diameter.

**Hydraulic circuit:** always install a pressure relief valve on the supply line to prevent the pressure from exceeding the allowed maximum. Normally, it is set in accordance with the weakest component in the system. (In the case where it is the pump, set the valve to a pressure 15% higher than the maximum pressure rating of the pump.)

Inlet line tubing should have a section equal to or greater than that of the inlet port of the pump. It is advisable to keep the tube connecting the pump to the reservoir as short possible. Particular care has to be taken with the inlet line which has to be hermetically sealed to avoid entraining air into the circuit; this varies the characteristics of the hydraulic fluid causing the operating parts to become damaged.

**Filtration:** the inlet line filter must have a flow rate capacity that is higher than that of the pump at its maximum operating speed. The filtration requirements for individual models are given in this catalogue. The use of a filter bypass is recommended for cold starts and should the filter become clogged. Proper maintenance of the filter element is essential for the correct operation of the entire system. In normal conditions replace the filter element after the first 50 hours of operation. Subsequently, replace it at least every 500 hours. Regarding the filter on the return line, the same general conditions apply as for the inlet line and it should be positioned in an accessible location for ease of maintenance.

**Tank:** if possible, the reservoir should be positioned above the pump. Otherwise, ensure that the minimum level of the fluid contained in it is higher than the pump inlet line opening. It is important to avoid draining the inlet line with the pump at standstill. The opening of the return line into the reservoir must remain below the minimum level of the fluid in the reservoir. It must not be positioned too close to the opening of the inlet line to avoid the possibility of any air bubbles passing into the inlet line. Baffles inside the reservoir may be useful in avoiding the problem. Rapid temperature changes can cause condensation on the underside of the lid of the reservoir with the formation of droplets of water that can fall into the oil. To avoid this problem it is recommended that the lid should have small vents so that the air space in the reservoir is ventilated. The vents have to be screened, though, to prevent the entry of dust or the sudden expulsion of fluid.

**Start-up:** use the following procedure when the pump is started-up for the first time:

- completely fill the pump and the inlet line with fluid;
  - start the engine for approximately one second a number of times at regular intervals of approximately 2 or 3 seconds until the noise level reduces, thereby confirming that it has been primed;
  - with a manometer check to ensure that the outlet pressure increases slightly;
  - once the pump has been primed, maintain low pressure levels activating all parts of the circuit a number of times until air bubbles disappear completely from the return line to the reservoir.
- This procedure should be carefully as any residual air inside the pump can quickly cause the rotor to seize.

**Cold starting:** when starting the pump, especially with low ambient temperatures, operate with moderate speed and pressure until the average temperature in the entire circuit is within the given limits.

The information provided in this catalogue is subject to change without notice