

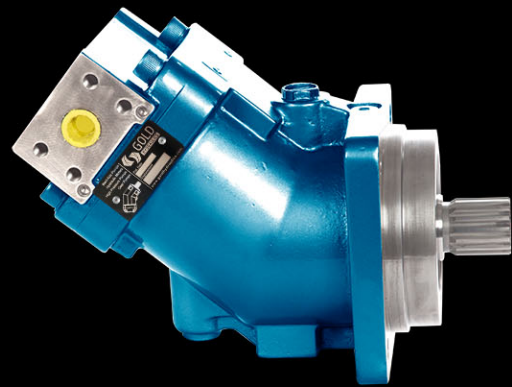

A8PO

Bent Axis Piston Pump

ISO Flange



A8PO Pumps have the following advantages ;

- Compact Design,
- Economical Conception,
- High Power Density,
- High Overall Efficiency,
- High Rotating Speeds,
- High Output Pressure,
- 350 bar Cont. Work. Pressure,
- 400 bar Peak Pressure,
- From 5cc to 130cc,
- Reduced Noise Level,
- Increased Reliability,
- No Drain Line Necessary,
- Smaller Installation Dimensions,
- One Piece Pistons with Piston Rings,
- Special Inlet Fittings & Accessories,
- Simple Change of Direction of Rotation

Other Advantages of A8PO

New frame sizes to meet market requirements.

For use in mobile & industrial and stationary applications areas.

The pump drive shaft bearings are designed to give the service life expected in these areas of operation.

Interchangeable with other ISO bent axis pumps.

40° bent axis design giving high power, small overall dimensions, optimum efficiency and economic design. Flange and shaft designed for direct mounting on truck gearbox PTO's. The fixed displacement bent axis pumps generates a hydraulic fluid flow. It is designed for use in trucks, commercial vehicles and all stationary hydraulic applications. The A8PO is a fixed pump with rotary group in bent-axis design open circuits. Flow is proportional to drive speed and displacement.

For axial piston units with bent-axis design, the Pistons are arranged diagonally with respect to the drive shaft. The pump covers the whole displacement range 5 to 130 cm³/rev. The pump has been developed with modern styling and design to satisfy market demand as to designed new generation plate and pistons with give high flow performance, high pressures with high efficiency and very small dimensions.

The pump is available both to DIN and SAE world standards and can be mounted either directly at the gear box or via a drive shaft. If necessary it can also be augmented with a by-pass valve. Other brand bent axis pumps compatible and interchangeable with A8PO bent axis pumps. Refer to the data sheet and order confirmation for the technical data, operating conditions and operating limits of the bent axis piston pumps.

Ordering Code of A8PO Pumps

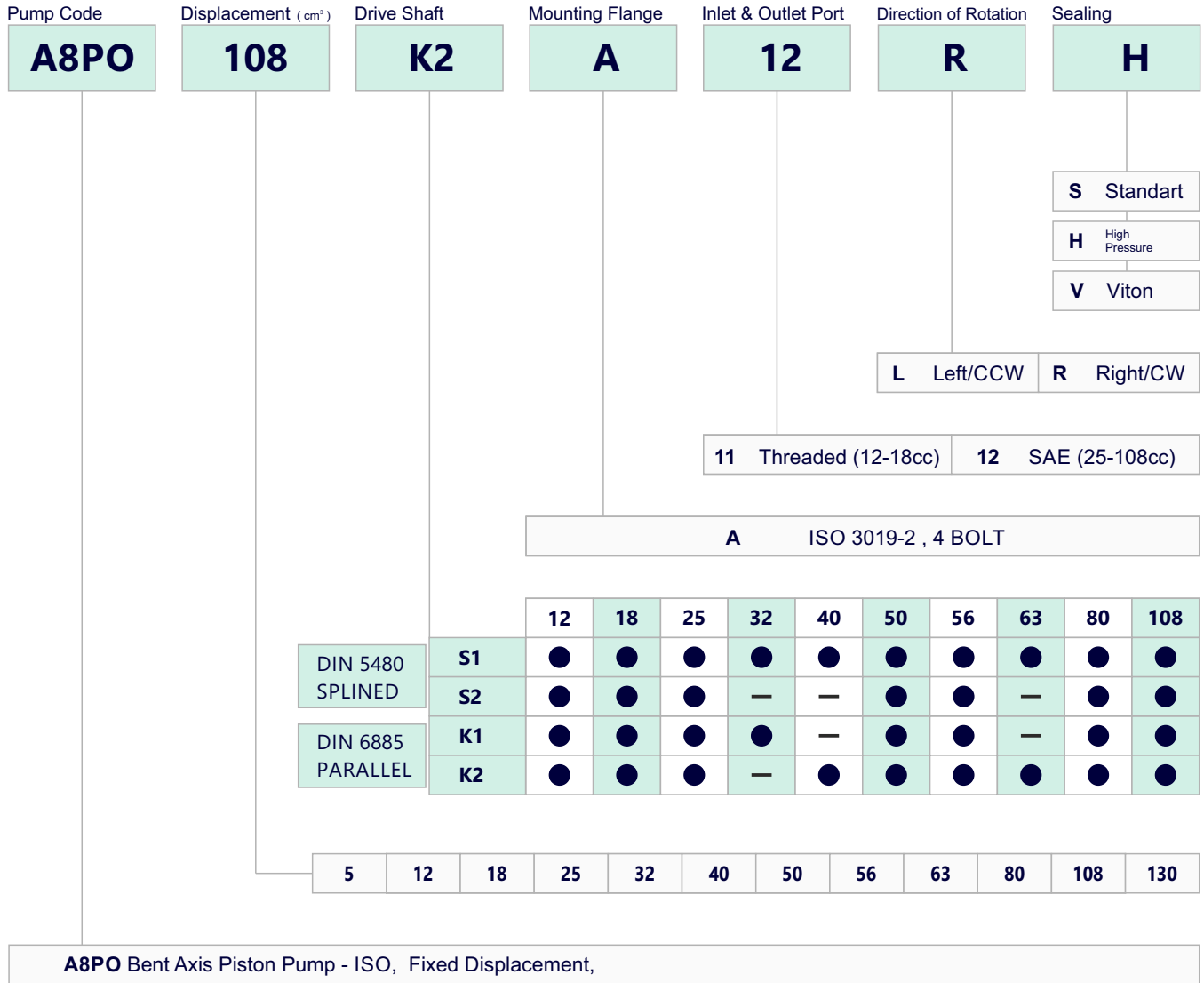

Technical Data

		5	12	18	25	32	40	50	56	63	80	108	130
Displacement	cc	5,00	12,00	18,00	25,00	32,00	40,20	50,00	56,40	63,00	80,00	108,4	130,0
Theoretical oil flow l/min at pump speed	1000 rpm	5,00	12,00	18,00	25,00	32,00	40,20	50,00	56,40	63,00	80,00	108,4	130,0
	1500 rpm	7,50	18,00	27,00	37,50	48,00	60,30	75,00	84,60	94,50	120,0	162,6	195,0
Maximum Pump Speed													
- Continuous	rpm	3300	3100	3100	2500	2500	2300	2300	2300	2300	2300	2000	1900
Max. Continuous Pressure	bar	400	400	400	400	400	400	400	400	400	400	400	400
Max. Peak Pressure	bar	450	450	450	450	450	450	450	450	450	450	450	450
Max. Torque at 350 bar	Nm	61	66	98	141	174	225	280	320	350	445	600	726
Max. Flow	l/min.	16,50	37,20	55,80	62,50	80,00	92,46	115,0	129,7	144,9	184,0	216,0	247,0
Pump Temperature													
- Minimum	°C	-25	-25	-25	-25	-25	-25	-25	-25	-25	-25	-25	-25
- Maximum	°C	110	110	110	110	110	110	110	110	110	110	110	110
Weight													
- Without accessories	kg	6,00	6,00	6,00	11,50	11,50	11,50	17,50	18,00	18,00	22,00	22,50	23,50
- With accessories	kg	6,20	6,20	6,20	11,80	11,90	11,90	18,00	18,50	18,50	22,50	23,00	24,00
Rotation		CW,CCW	CW,CCW	CW,CCW	CW,CCW	CW,CCW	CW,CCW	CW,CCW	CW,CCW	CW,CCW	CW,CCW	CW,CCW	CW,CCW

Quick Calculation

$$\text{Flow } Q = \frac{V_g \cdot n \cdot \eta_v}{1000} \quad \text{l/min}$$

$$\text{Torque } T = \frac{V_g \cdot \Delta P}{20 \cdot \pi \cdot \eta_{mh}} \quad \text{N}\cdot\text{m}$$

$$\text{Power } N = \frac{Q \cdot \Delta P}{612 \cdot \eta_t} \quad \text{kW}$$

- Q – flow, l/min
- T – torque, N•m
- N – power, kW
- V_g – displacement, ccm/rev
- n – shaft speed, rpm
- ΔP – pressure difference, bar
- η_v – volume efficiency
- η_{mh} – hydraulic mechanical efficiency
- $\eta_t = \eta_v \cdot \eta_{mh}$ – full efficiency coefficient

Performance

Efficiency Curves (1000 rpm)

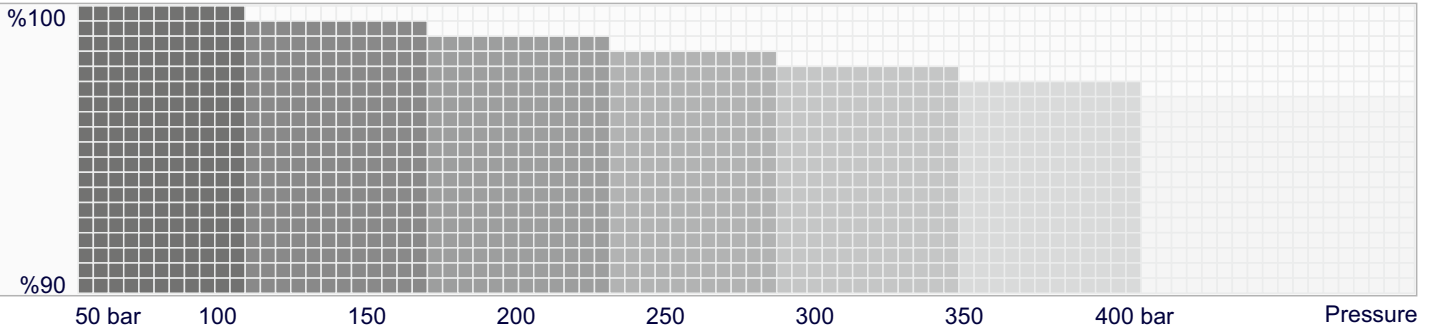

Torque with Pump Output Pressure

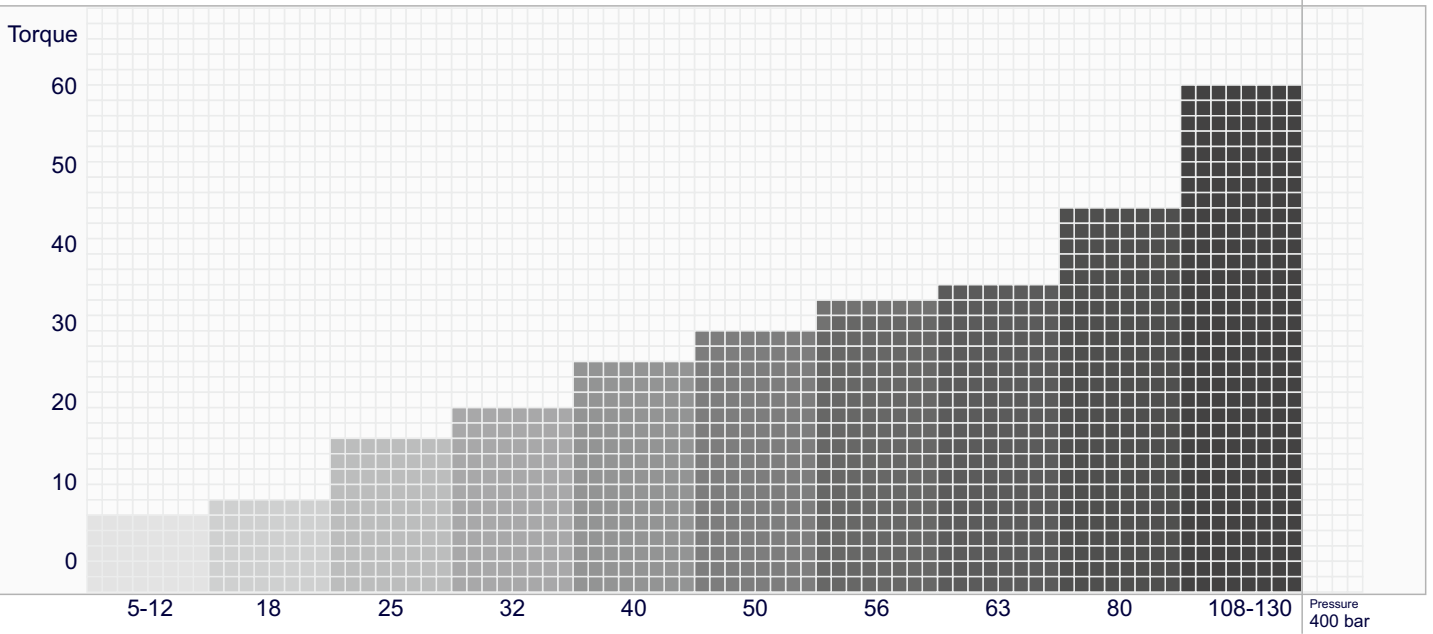

Flow with Pump Speed

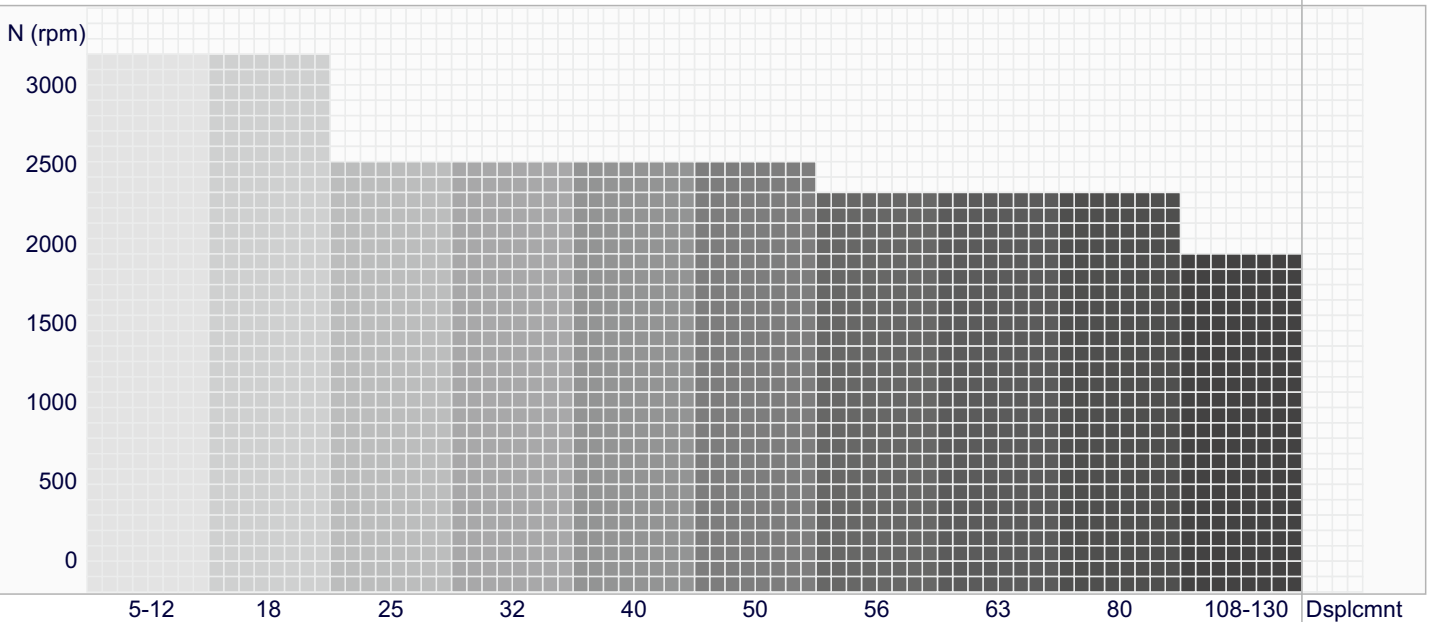

A8PO 5

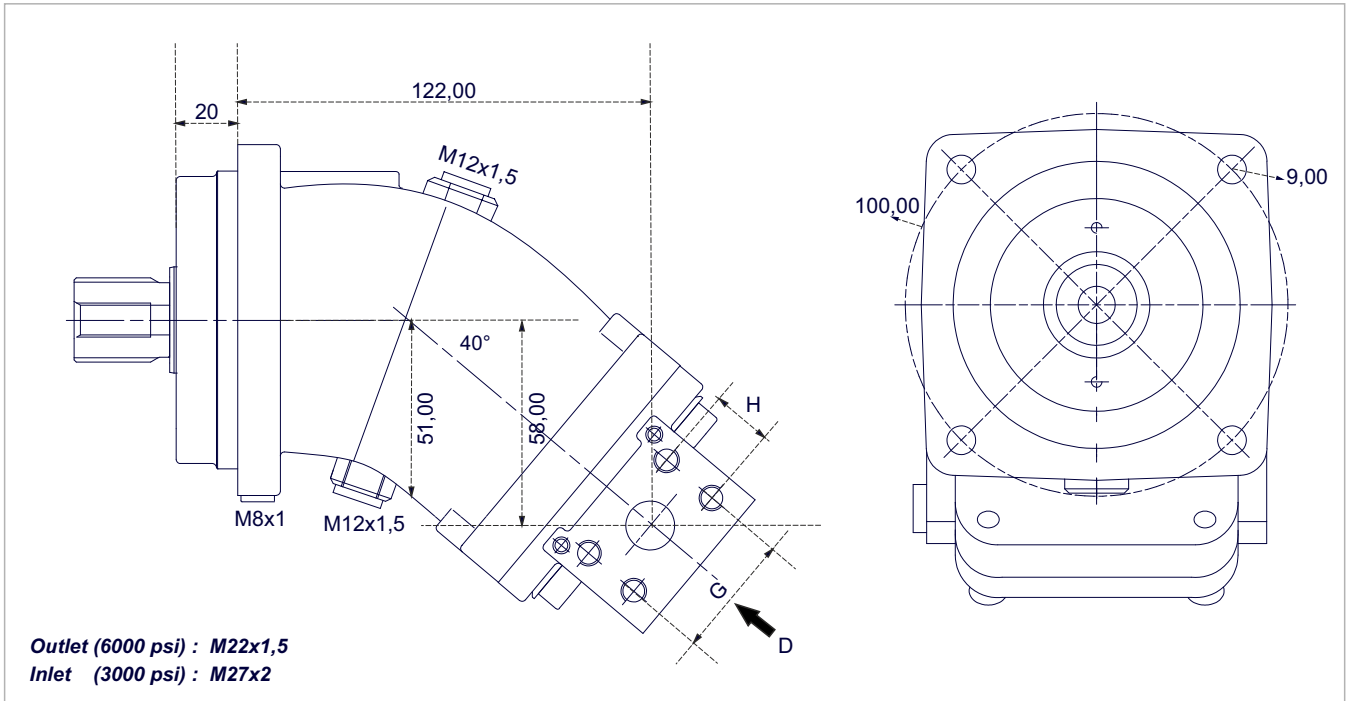

x 1000 rpm	5,00 cc
x 1500 rpm	7,50 cc
Max. Continuous Pump Speed	3300 rpm
Max. Continuous Pressure	400 bar
Max. Peak Pressure	450 bar
Max. Torque at 350 bar	61 Nm
Max. Flow	16,50 l/min.
Min. Pump Temperature	-25 °C
Max. Pump Temperature	110 °C
Weight without accessories	6,00 kg
Weight with accessories	6,20 kg
Rotation	CW-CCW

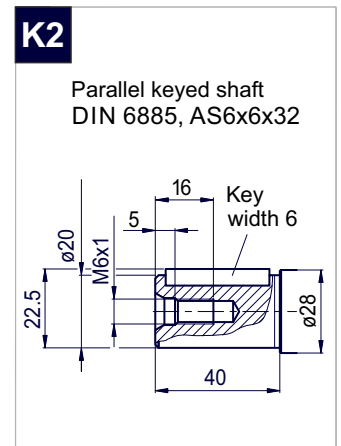
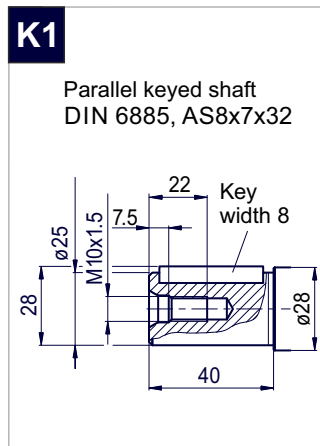
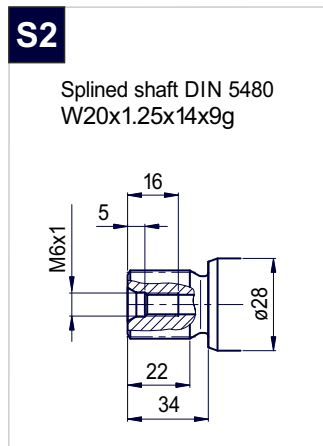
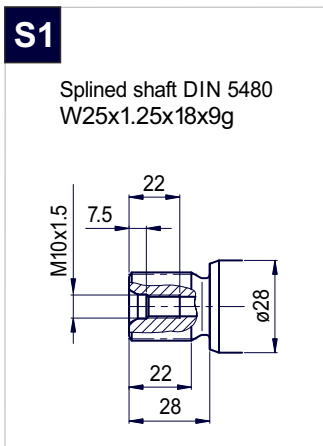
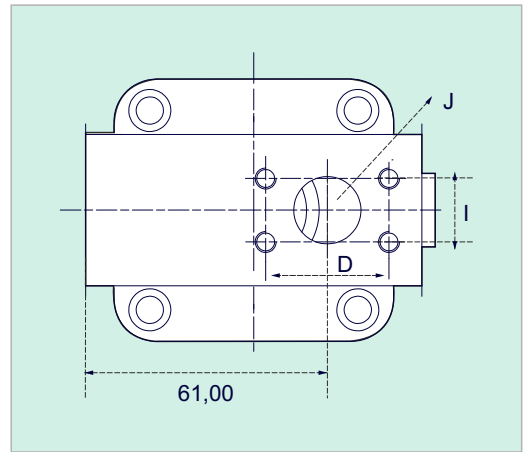

A8PO 12

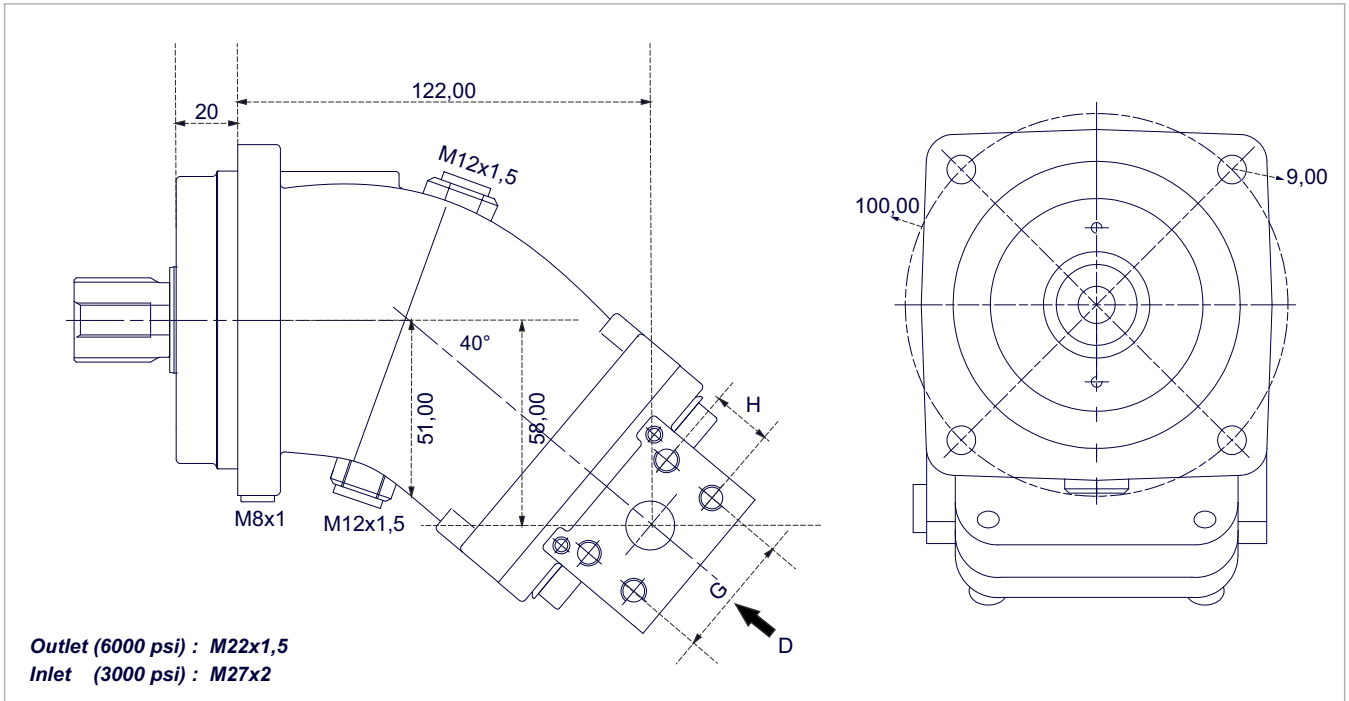

x 1000 rpm	12,00 cc
x 1500 rpm	18,00 cc
Max. Continuous Pump Speed	3100 rpm
Max. Continuous Pressure	400 bar
Max. Peak Pressure	450 bar
Max. Torque at 350 bar	66 Nm
Max. Flow	37,20 l/min.
Min. Pump Temperature	-25 °C
Max. Pump Temperature	110 °C
Weight without accessories	6,00 kg
Weight with accessories	6,20 kg
Rotation	CW-CCW

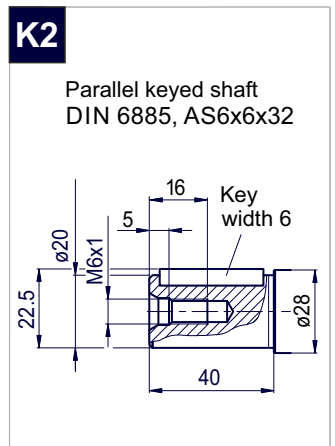
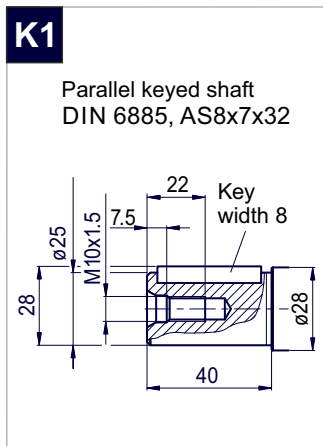
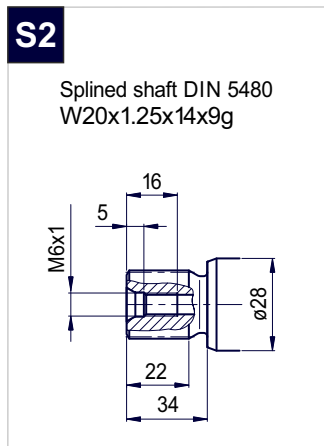
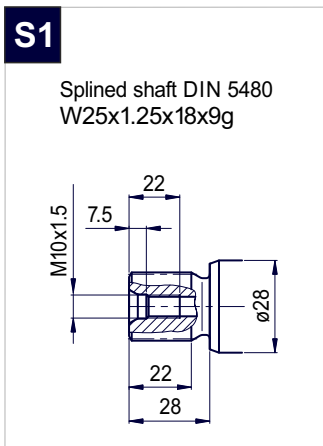
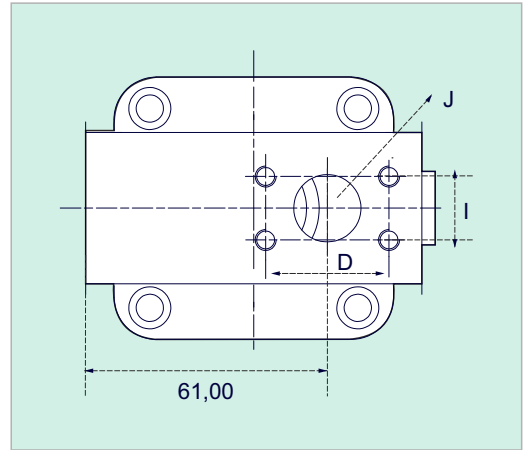

A8PO 18

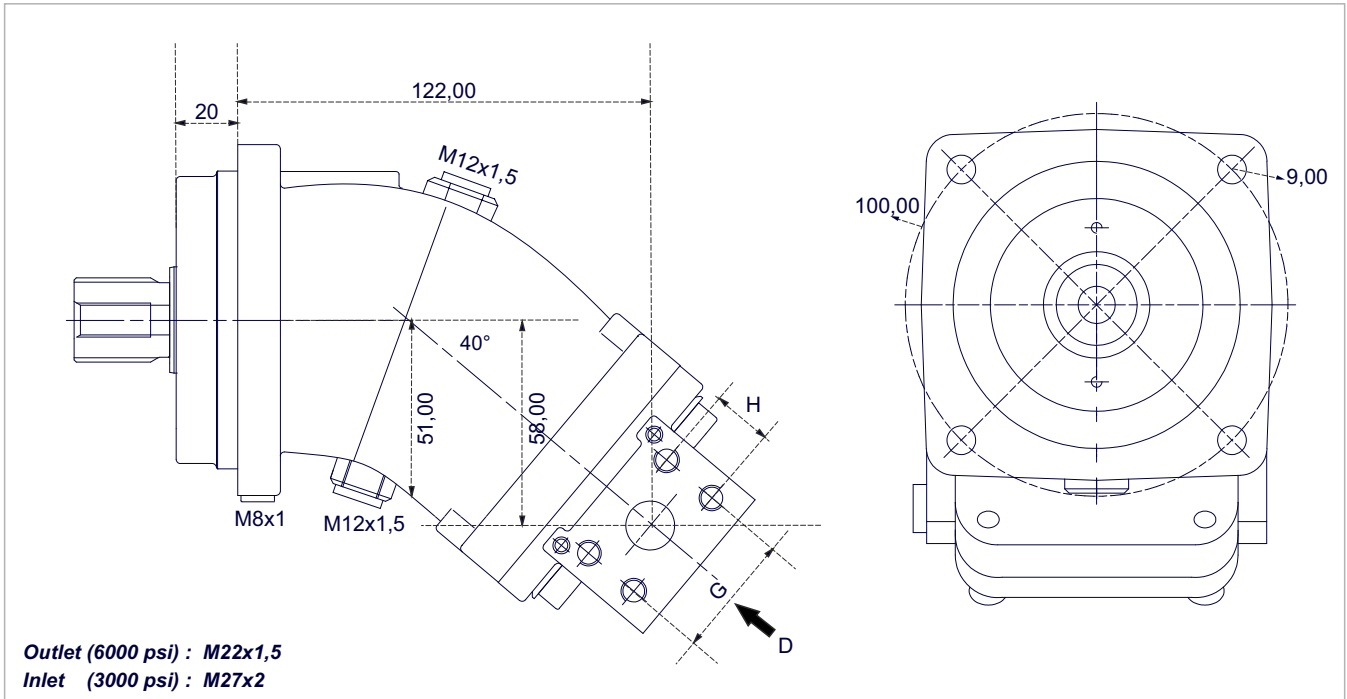

x 1000 rpm	18,00 cc
x 1500 rpm	27,00 cc
Max. Continuous Pump Speed	3100 rpm
Max. Continuous Pressure	400 bar
Max. Peak Pressure	450 bar
Max. Torque at 350 bar	98 Nm
Max. Flow	55,80 l/min.
Min. Pump Temperature	-25 °C
Max. Pump Temperature	110 °C
Weight without accessories	6,00 kg
Weight with accessories	6,20 kg
Rotation	CW-CCW

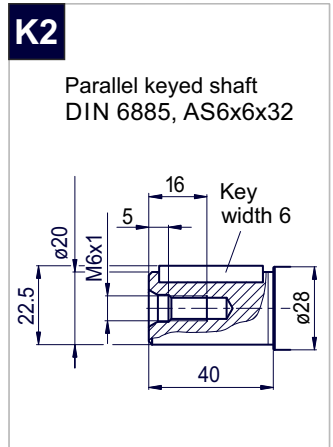
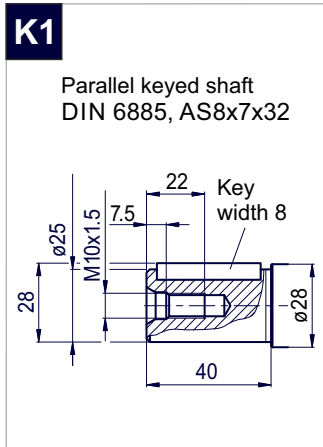
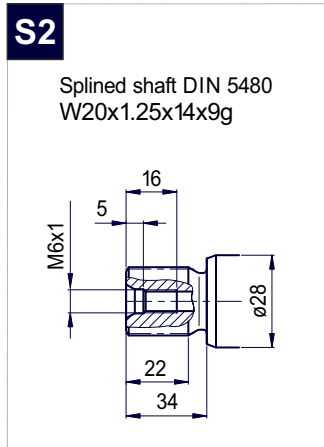
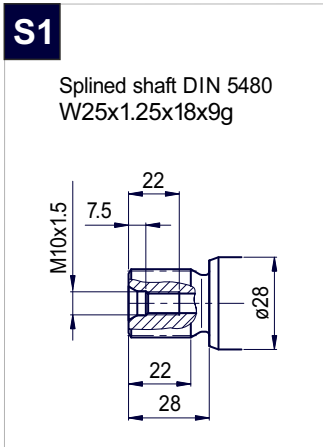
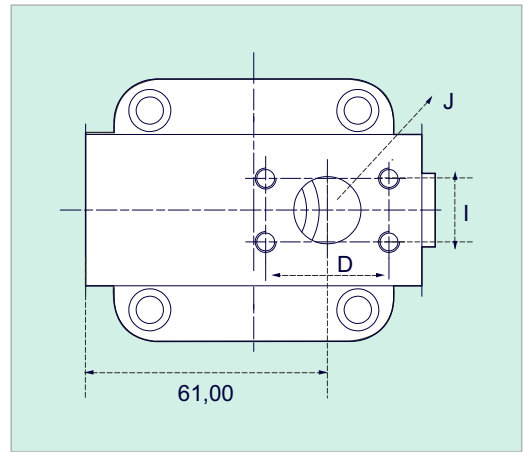

A8PO 25

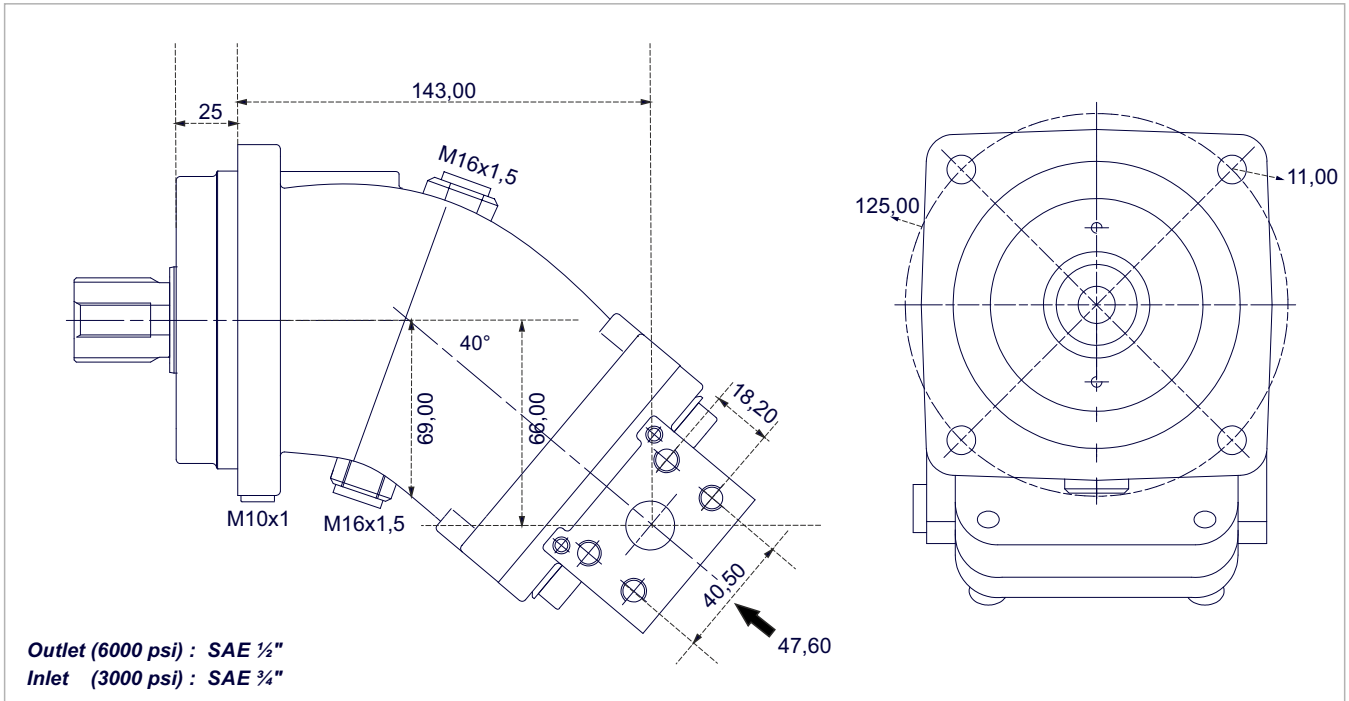

x 1000 rpm	25,00 cc
x 1500 rpm	37,50 cc
Max. Continuous Pump Speed	2500 rpm
Max. Continuous Pressure	400 bar
Max. Peak Pressure	450 bar
Max. Torque at 350 bar	141 Nm
Max. Flow	62,50 l/min.
Min. Pump Temperature	-25 °C
Max. Pump Temperature	110 °C
Weight without accessories	11,50 kg
Weight with accessories	11,80 kg
Rotation	CW-CCW

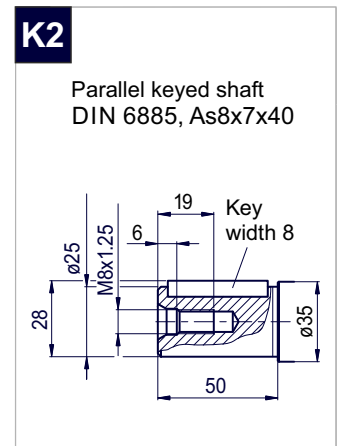
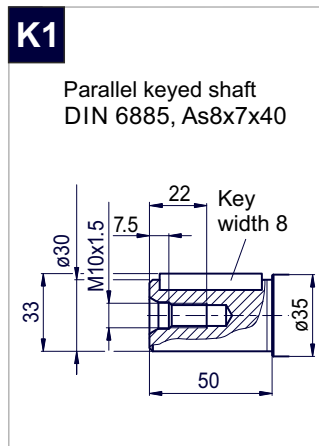
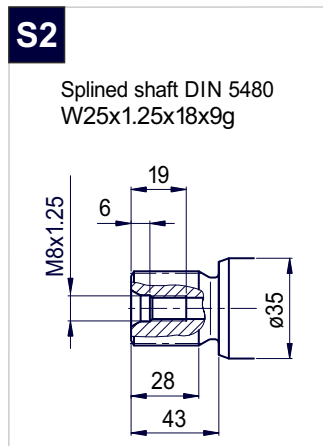
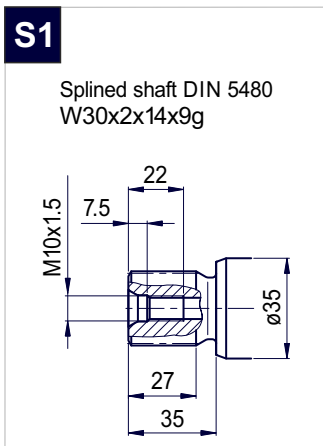
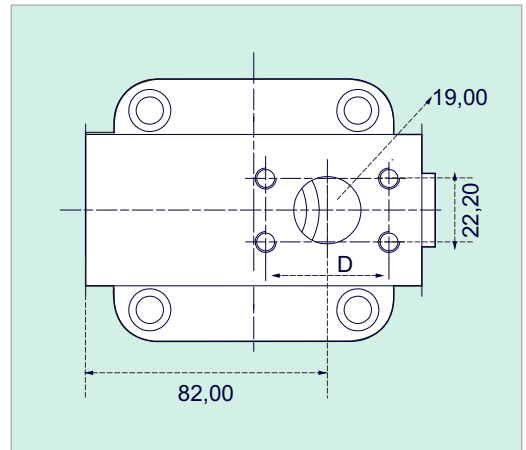

A8PO 32

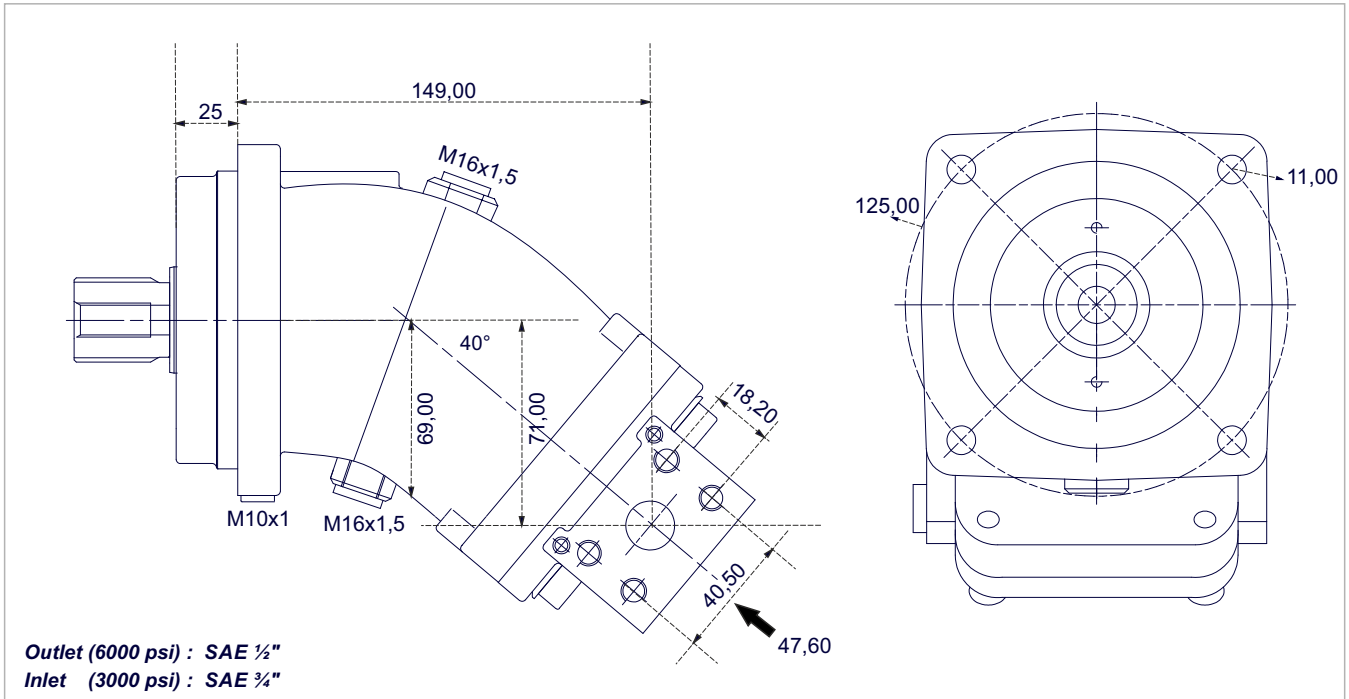

x 1000 rpm	32,00 cc
x 1500 rpm	48,00 cc
Max. Continuous Pump Speed	2500 rpm
Max. Continuous Pressure	400 bar
Max. Peak Pressure	450 bar
Max. Torque at 350 bar	174 Nm
Max. Flow	80,00 l/min.
Min. Pump Temperature	-25 °C
Max. Pump Temperature	110 °C
Weight without accessories	11,50 kg
Weight with accessories	11,90 kg
Rotation	CW-CCW

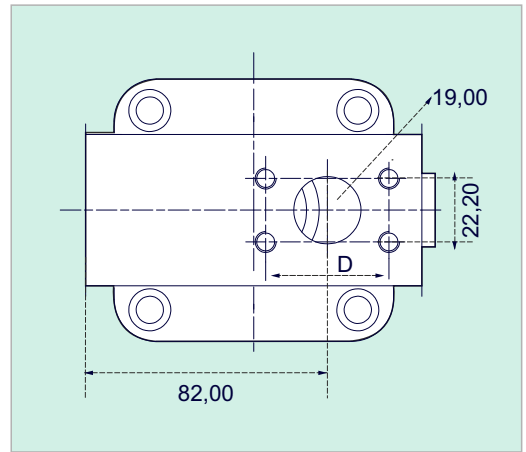

S1

Splined shaft DIN 5480
 W30x2x14x9g

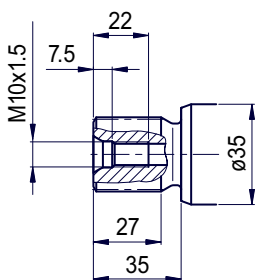

K1

Parallel keyed shaft
 DIN 6885, As8x7x40

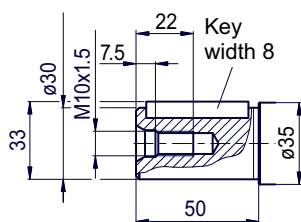

A8PO 40

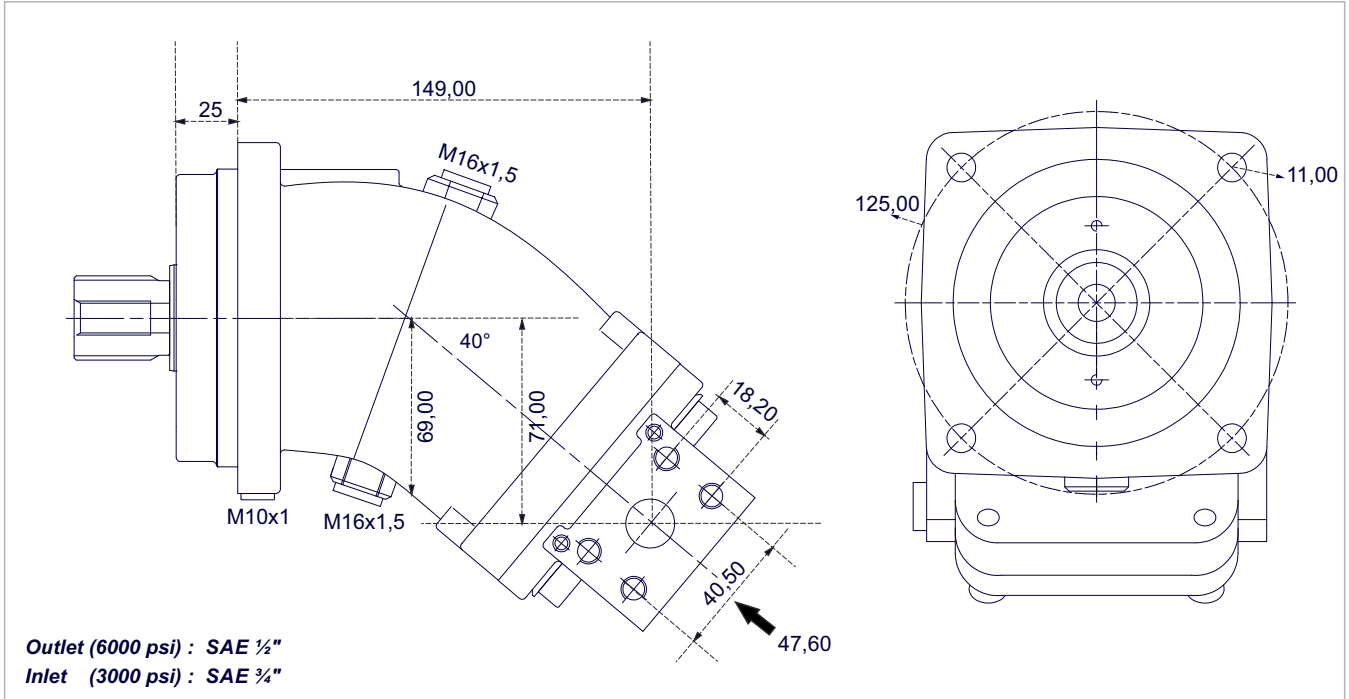

x 1000 rpm	40,20 cc
x 1500 rpm	60,30 cc
Max. Continuous Pump Speed	2300 rpm
Max. Continuous Pressure	400 bar
Max. Peak Pressure	450 bar
Max. Torque at 350 bar	225 Nm
Max. Flow	92,46 l/min.
Min. Pump Temperature	-25 °C
Max. Pump Temperature	110 °C
Weight without accessories	11,50 kg
Weight with accessories	11,90 kg
Rotation	CW-CCW

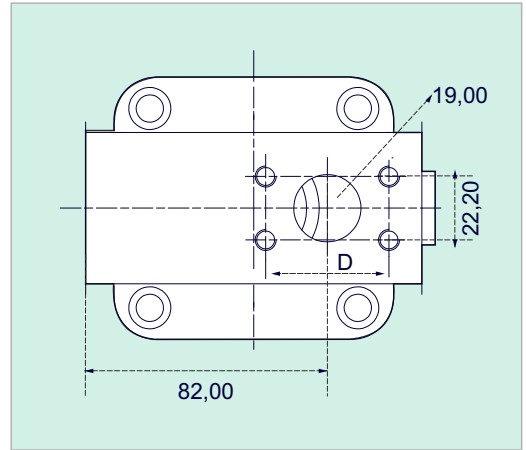

S1

Splined shaft DIN 5480
 W30x2x14x9g

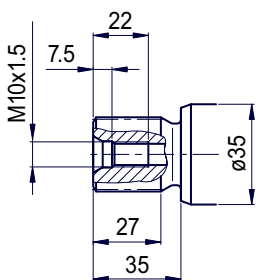

K2

Parallel keyed shaft
 DIN 6885, As8x7x40

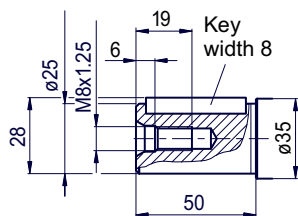

A8PO 50

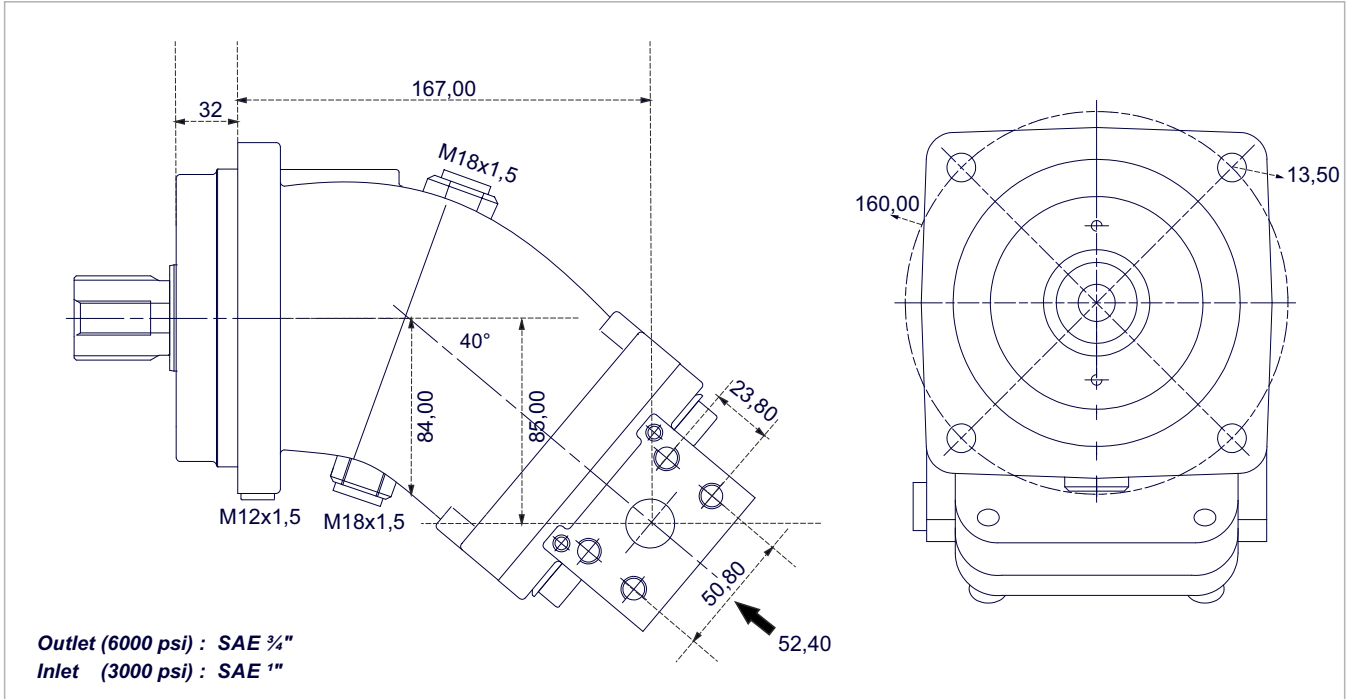

x 1000 rpm	50,00 cc
x 1500 rpm	75,00 cc
Max. Continuous Pump Speed	2300 rpm
Max. Continuous Pressure	400 bar
Max. Peak Pressure	450 bar
Max. Torque at 350 bar	280 Nm
Max. Flow	115,00 l/min.
Min. Pump Temperature	-25 °C
Max. Pump Temperature	110 °C
Weight without accessories	17,50 kg
Weight with accessories	18,00 kg
Rotation	CW-CCW

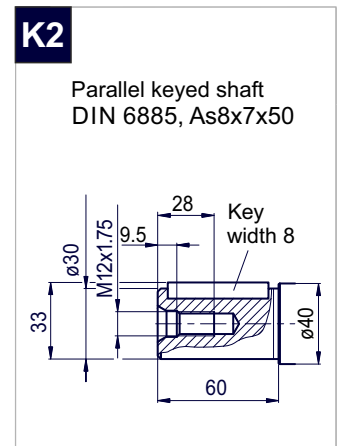
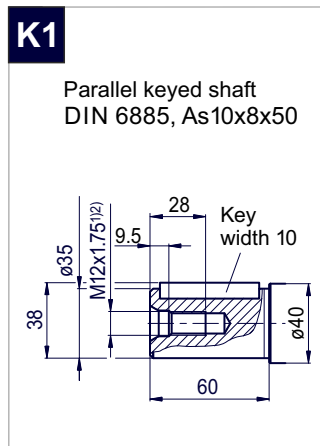
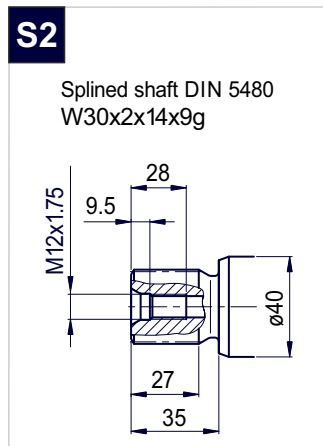
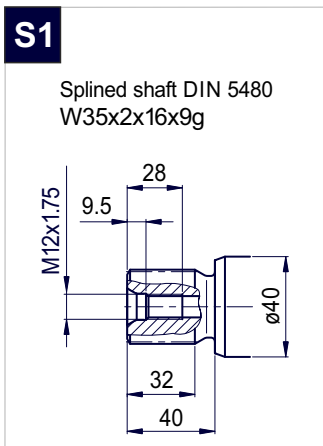
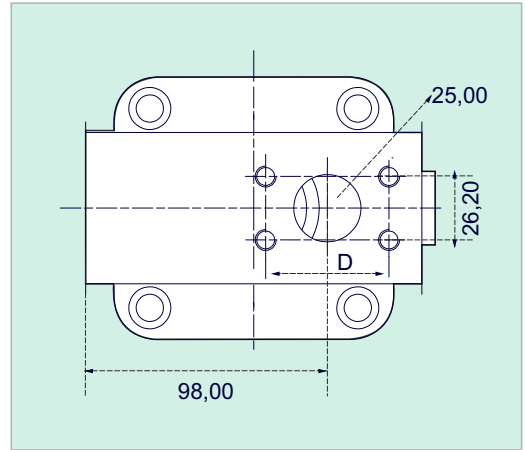

A8PO 56

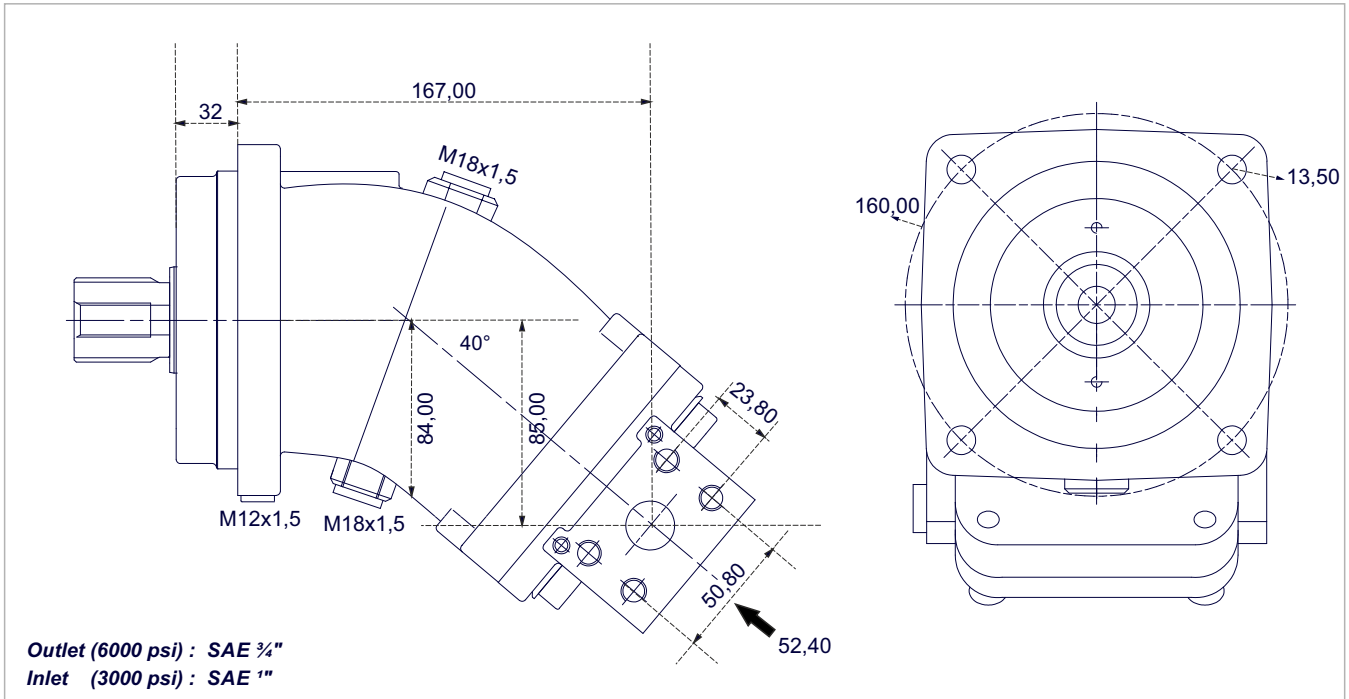

x 1000 rpm	56,40 cc
x 1500 rpm	84,60 cc
Max. Continuous Pump Speed	2300 rpm
Max. Continuous Pressure	400 bar
Max. Peak Pressure	450 bar
Max. Torque at 350 bar	320 Nm
Max. Flow	129,70 l/min.
Min. Pump Temperature	-25 °C
Max. Pump Temperature	110 °C
Weight without accessories	18,00 kg
Weight with accessories	18,50 kg
Rotation	CW-CCW

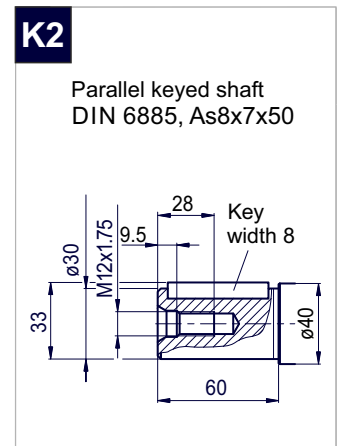
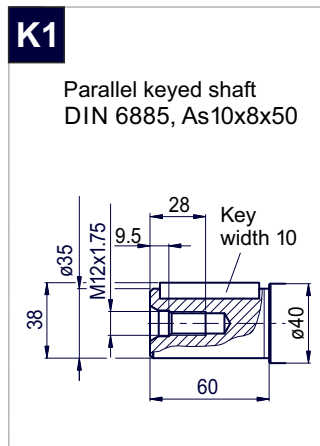
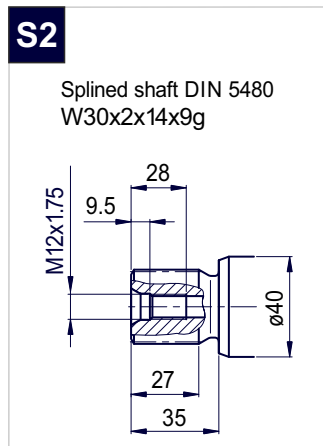
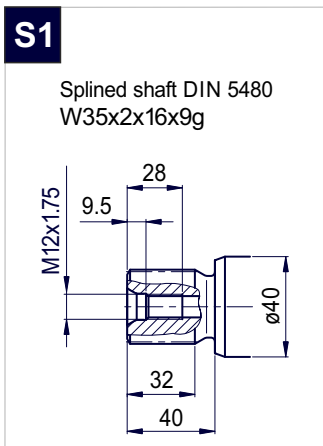
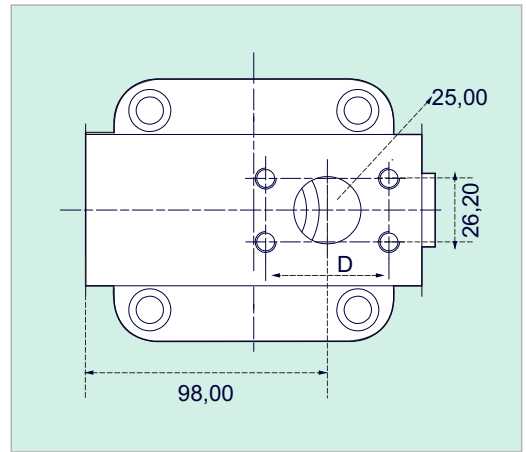

A8PO 63

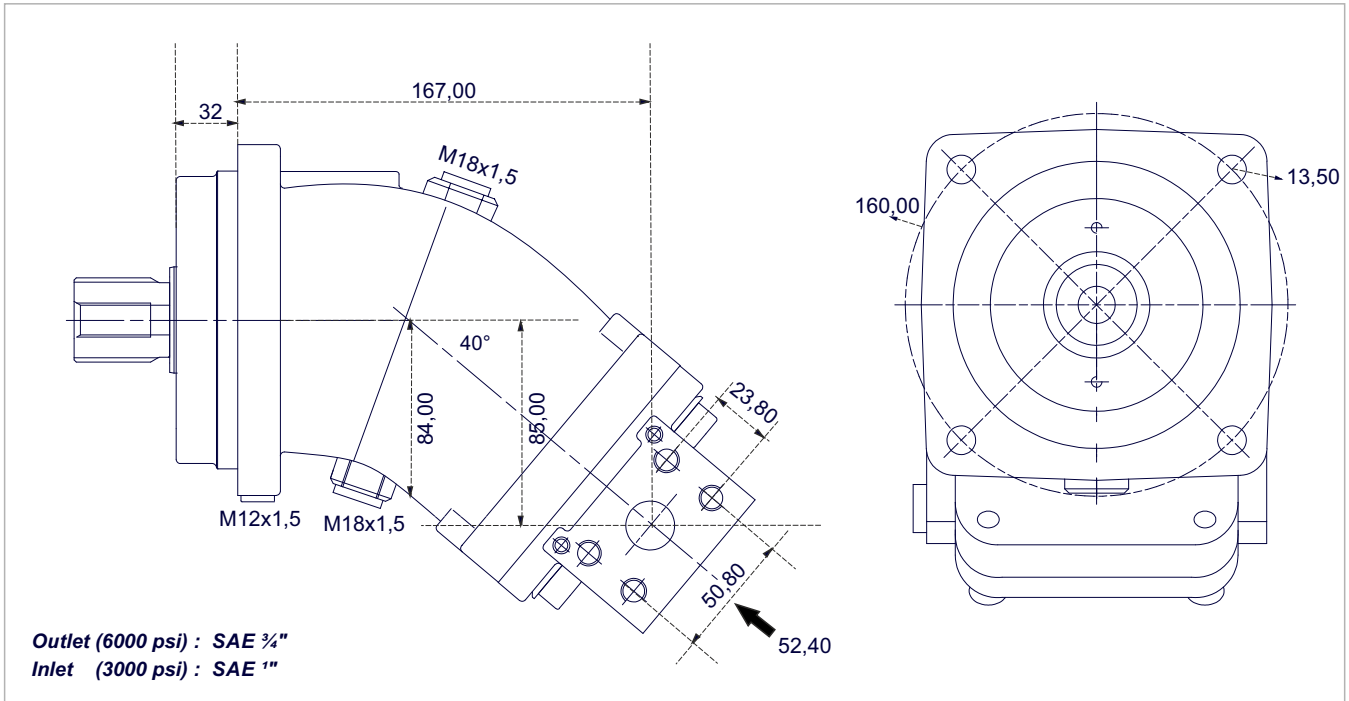

x 1000 rpm	63,00 cc
x 1500 rpm	94,50 cc
Max. Continuous Pump Speed	2300 rpm
Max. Continuous Pressure	400 bar
Max. Peak Pressure	450 bar
Max. Torque at 350 bar	350 Nm
Max. Flow	144,90 l/min.
Min. Pump Temperature	-25 °C
Max. Pump Temperature	110 °C
Weight without accessories	18,00 kg
Weight with accessories	18,50 kg
Rotation	CW-CCW

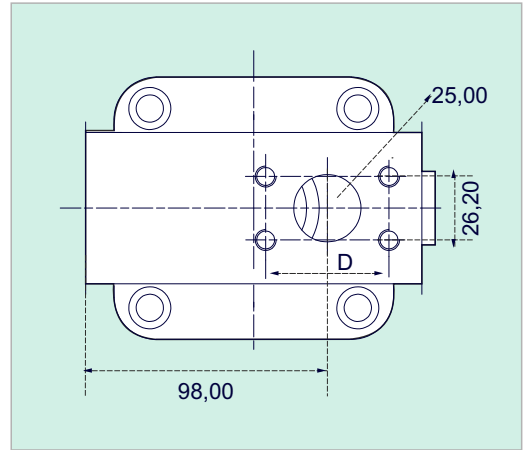

S1

Splined shaft DIN 5480
W35x2x16x9g

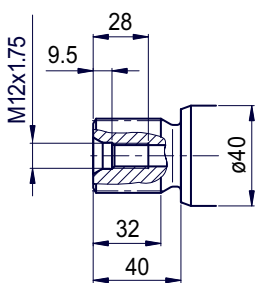

K1

Parallel keyed shaft
DIN 6885, As10x8x50

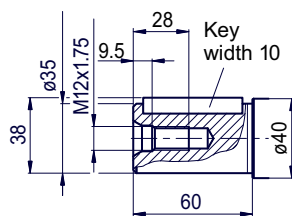

A8PO 80

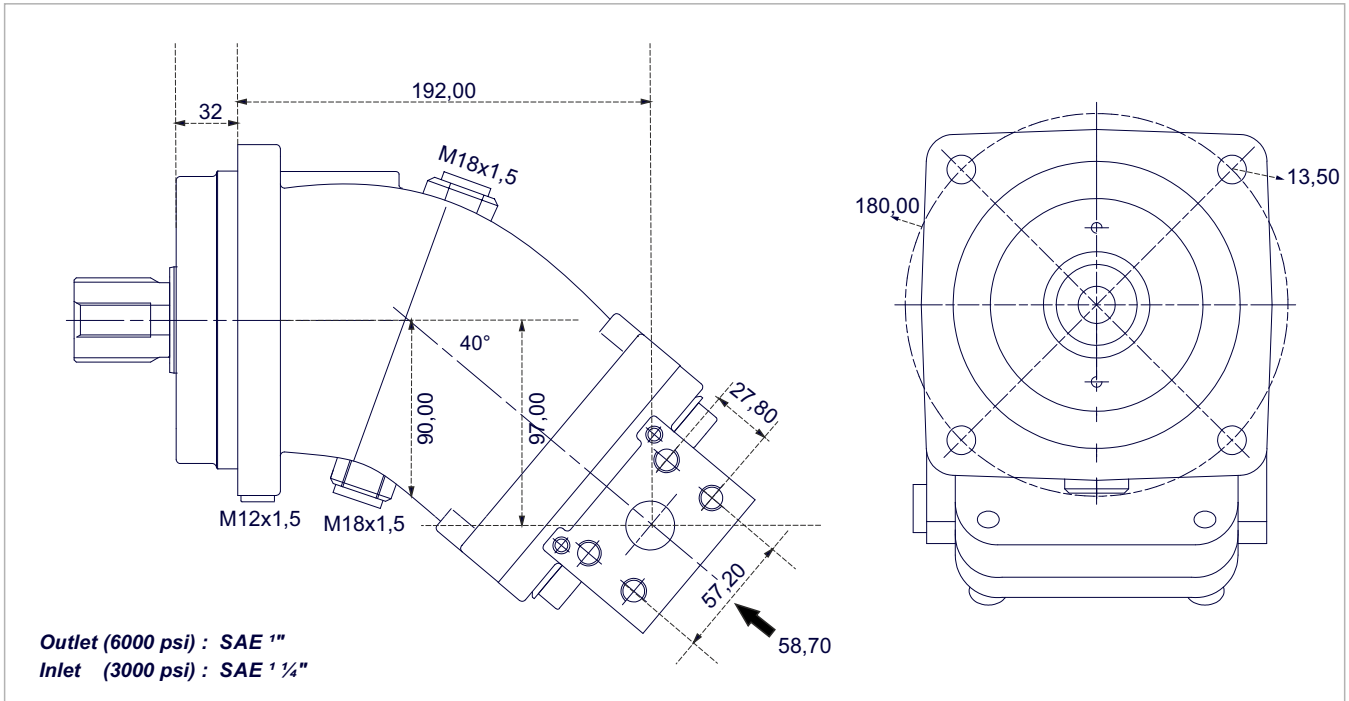

x 1000 rpm	80,00 cc
x 1500 rpm	120,00 cc
Max. Continuous Pump Speed	2300 rpm
Max. Continuous Pressure	400 bar
Max. Peak Pressure	450 bar
Max. Torque at 350 bar	445 Nm
Max. Flow	184,00 l/min.
Min. Pump Temperature	-25 °C
Max. Pump Temperature	110 °C
Weight without accessories	22,00 kg
Weight with accessories	22,50 kg
Rotation	CW-CCW

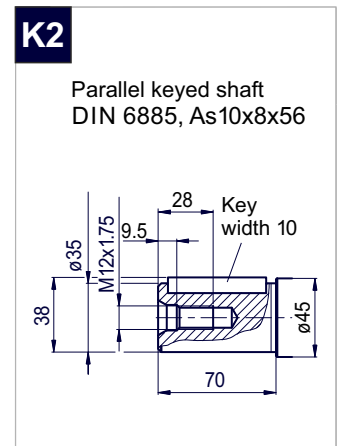
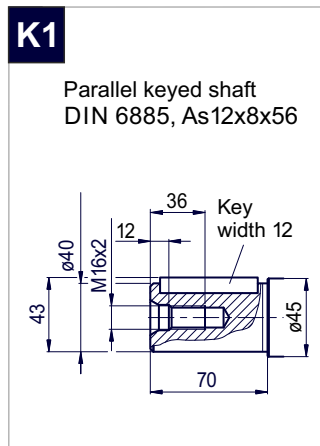
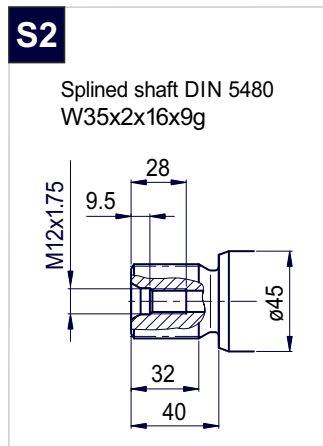
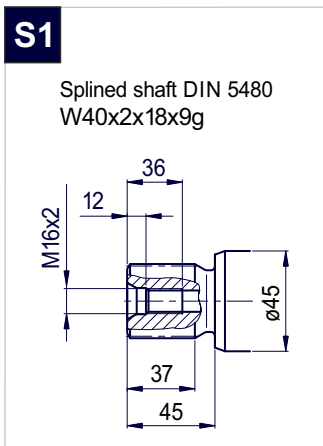
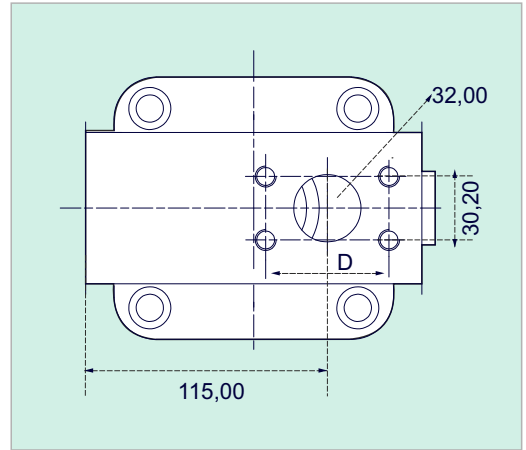

A8PO 108

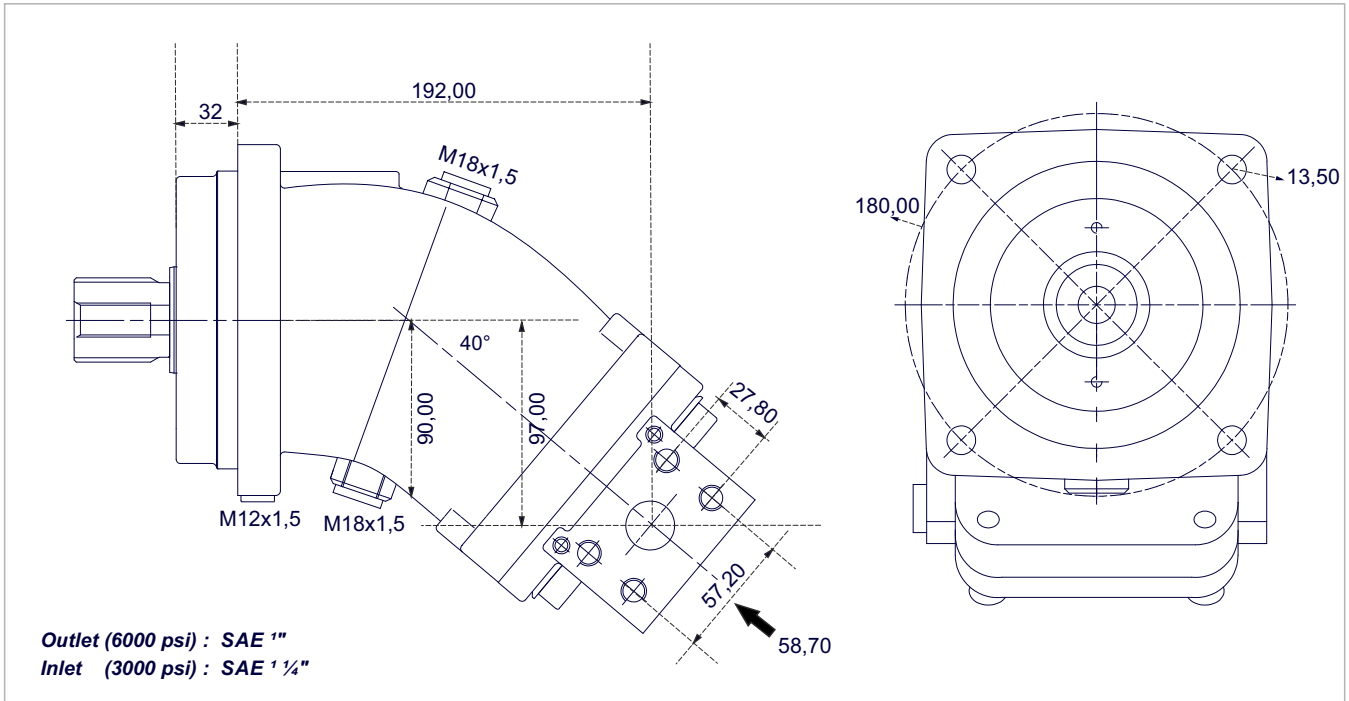

x 1000 rpm	108,40 cc
x 1500 rpm	162,60 cc
Max. Continuous Pump Speed	2000 rpm
Max. Continuous Pressure	400 bar
Max. Peak Pressure	450 bar
Max. Torque at 350 bar	600 Nm
Max. Flow	216,00 l/min.
Min. Pump Temperature	-25 °C
Max. Pump Temperature	110 °C
Weight without accessories	22,50 kg
Weight with accessories	23,00 kg
Rotation	CW-CCW

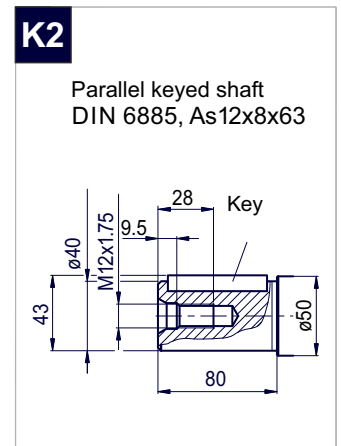
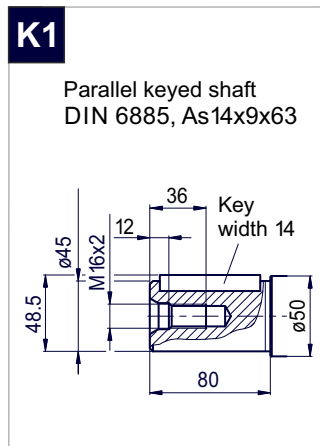
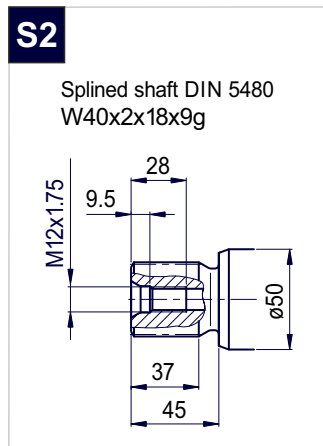
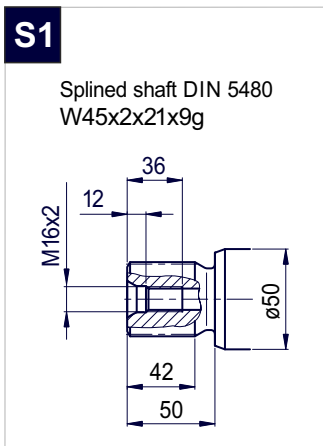
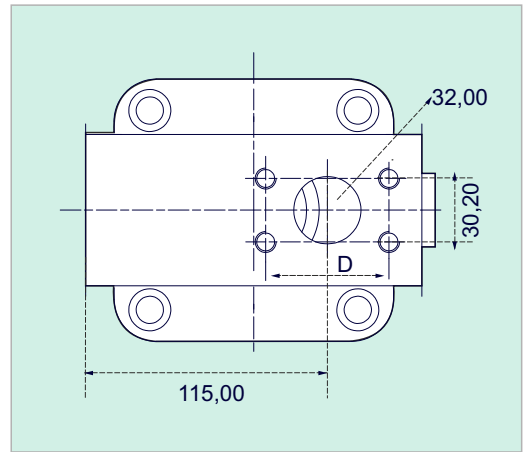

A8PO 130

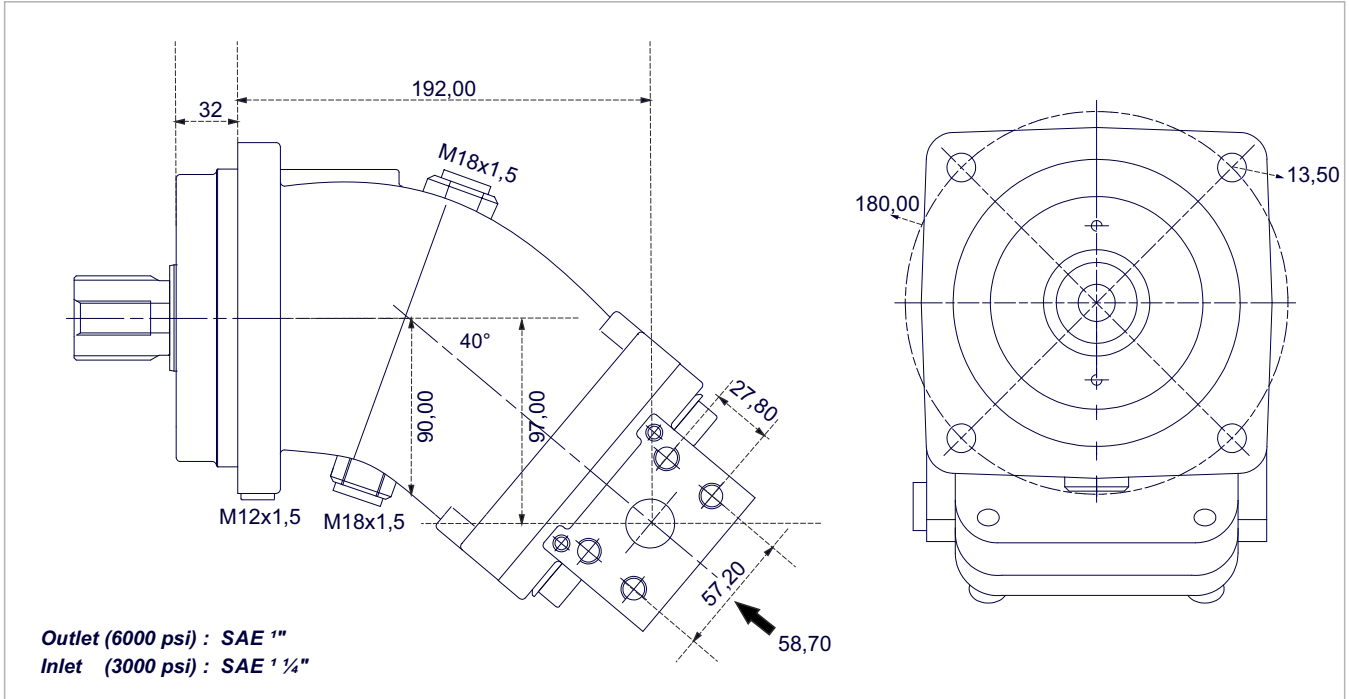

x 1000 rpm	130,00 cc
x 1500 rpm	195,00 cc
Max. Continuous Pump Speed	1900 rpm
Max. Continuous Pressure	400 bar
Max. Peak Pressure	450 bar
Max. Torque at 350 bar	726 Nm
Max. Flow	247,00 l/min.
Min. Pump Temperature	-25 °C
Max. Pump Temperature	110 °C
Weight without accessories	23,50 kg
Weight with accessories	24,00 kg
Rotation	CW-CCW

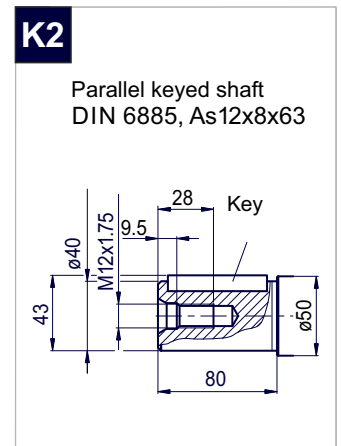
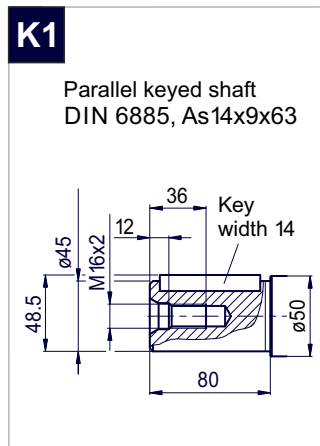
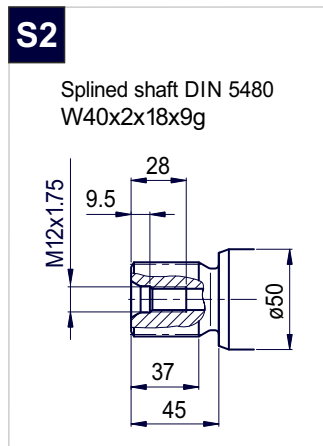
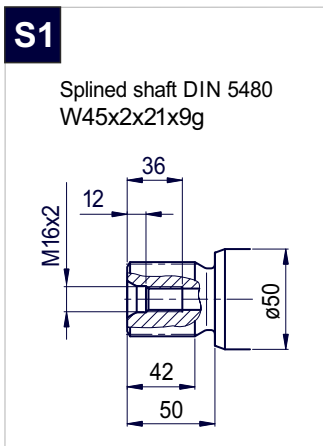
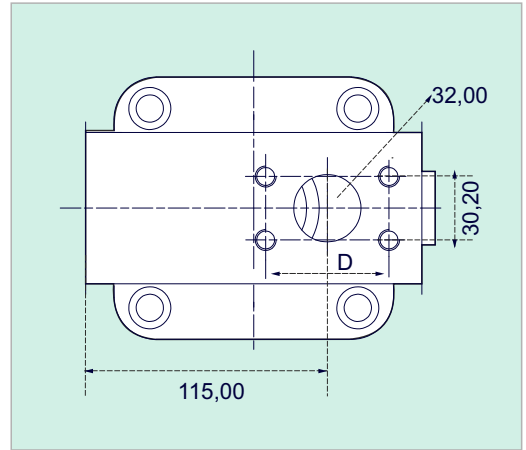

Special Shaft Drive & Special Back Cover

Splined shaft
35xf7x2x9g GOST 6033-80

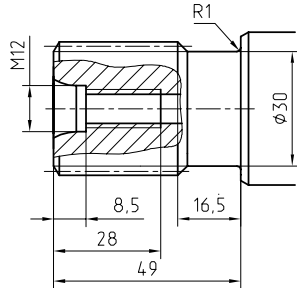

35xf7x2x9g ГOCT6033

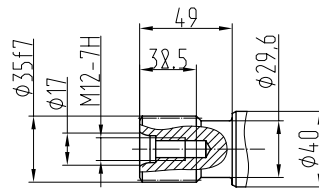

Parallel keyed shafts

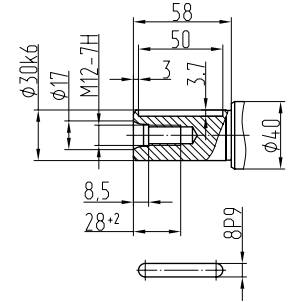

Parallel keyed shafts

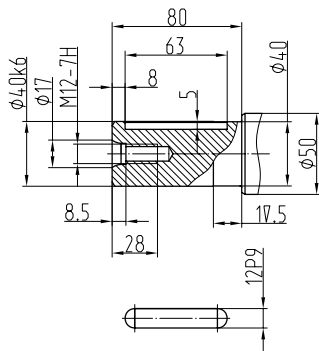

1 3/8' 21T 16/32DP ANSI B92

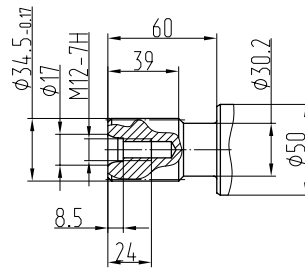

Parallel keyed shafts

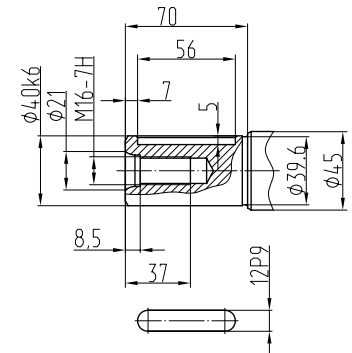

1 1/2' 23T 16/32DP ANSI B92

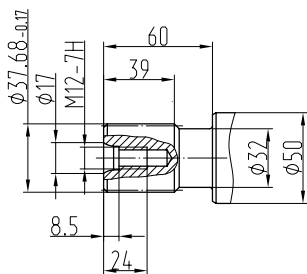

40xf7x2x9g GOST6033

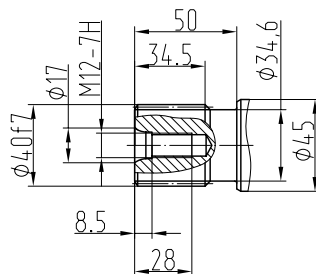

45xh8x2x9g GOST 6033-80

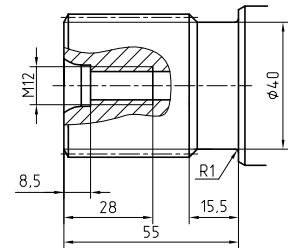

Special Cover / Rotation : LEFT

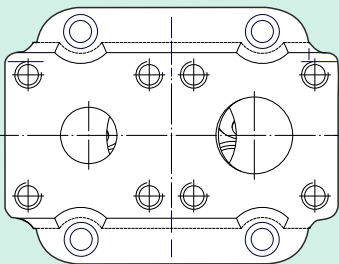

Special Cover / Rotation : RIGHT

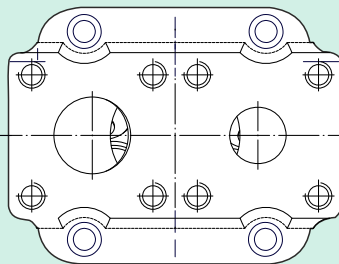

Installation

The A8PO Pumps can be operate any position.
See following examples.

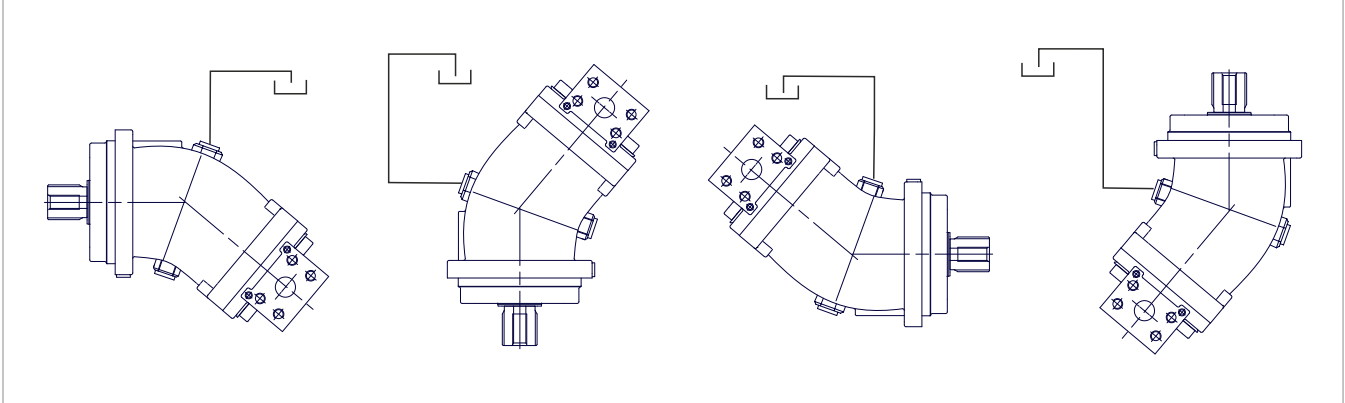

OIL SUPPLY

Oil and supply line should be clean, and the supply line is airtight.

SUCTION LINE

Connect the suction line, tighten the suction connection bolts in diametric pairs.
Connect the pressure line.

REPAIR

We offers a comprehensive range of services for the repair of our Bent Axis Pumps.
Repairs to the A8PO Bent Axis Pump may only be performed by authorized, skilled and instructed personnel.
Only use original and pre-installed our A8PO spare parts from supplied to Manufacturer..

Tested and pre-installed A8PO pumps successful repair requiring only little time.

SPARE PARTS

The spare parts list and the A8PO pump order specific.
When ordering spare parts, quote the material and complete Ordering code number of the A8PO Bent Axis Pump as well as the right numbers of the spare parts.

RISK OF DAMAGE!

Do not touch the drive shaft of the A8PO Bent Axis Pump
Do not touch sensor, valves and fittings
Do not touch sealing surfaces.

DIMENSIONS & WEIGHTS

Weight													
- Without accessories	kg	6,00	6,00	6,00	11,50	11,50	11,50	17,50	18,00	18,00	22,00	22,50	23,50
- With accessories	kg	6,20	6,20	6,20	11,80	11,90	11,90	18,00	18,50	18,50	22,50	23,00	24,00

Address all questions regarding spare parts to your responsible Our Service Partner or the technical service department of the manufacture's plant / factory for the A8PO Bent Axis Pumps.

Complete Product Range

Piston Pumps

Piston Motors

DIN

DIN 5462 / ISO 14
8x32x35
8x32x36
DIN 6885



A8PD



A9MD

ISO

ISO 3019-2 (4 BOLTS)
DIN 5480 -W25,30,35,40,45
DIN 6885 -Ø20,25,30,35,40,45



A8PO



A9MO

SAE

SAE B2 C4 - SAE D
SAE J498b
SAE J 744



A8PS



A9MS

M2

Fixed Plug-in

DIN 5480 / ISO 3019-2
W30 - W35 - W40
M21 - M22 - M23



A8PL - Dual Flow

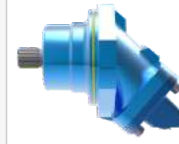

A9MF - Semi integrated

A4

DIN ISO 14
8x32x36



A4PP Single Flow



A4PL Dual Flow

A6

P2 Connection M8x125
Woodruff key 3x6,5 NF E
27-653 NF R 124-04
(2 BOLTS)



A6HP - High Pressure



**A7GP - Gear Pump
A7GM - Gear Motor**

Contact



Gold Hydraulics, Ltd.

2019® Catalogue

All pictures and banners are patented by owner.

www.goldhydraulics.com

For more details and other catalogs,
please send email to our team.

Hydraulic Bent Axis Piston Pumps
Bent Axis Motors
Dual Flow Piston Pumps and Gear Pumps...

Sales Team

info@goldhydraulics.com

Order

order@goldhydraulics.com

Management

mail@goldhydraulics.com



www.goldhydraulics.com